

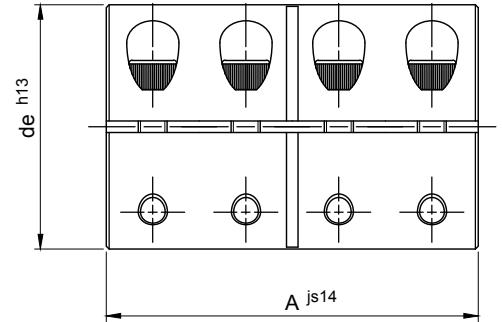

GIUNTI RIGIDI AD UNA SEZIONE CON CHIAVETTA - BRUNITI

RIGID COUPLING ONE SPLIT BORE AND KEYWAY - BLACK OXIDE

Momenti torcenti medio elevati
 Tolleranza: albero h8
 Superficie di contatto con rugosità: R_a max 16 μm
 Montaggio e smontaggio rapido fra due alberi allineati
 Massima velocità 4000 min^{-1}
 Cave linguette secondo DIN 6885 / UNI 6604

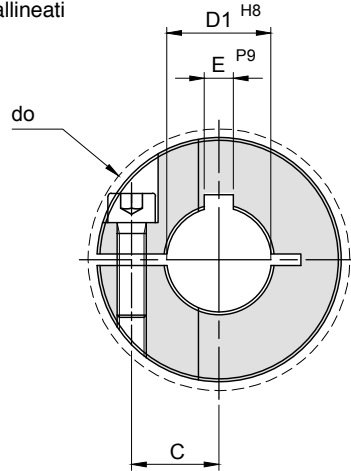

Materiale: Acciaio C-45

descrizione	codice	D1 mm	de mm	do mm	A mm	momento torcente Mt Nm	C mm	E mm	viti di serraggio			Kg.
									DIN 912 12,9 N°	coppia di serraggio Ms Nm tipo		
GBR 6	GBR006	6	18	21,5	30	30	5,9	2	4	M3 x 8	2,1	0,05
GBR 8	GBR008	8	24	27,1	35	50	9,0	2	4	M3 x 10	2,1	0,10
GBR 10	GBR010	10	29	33,0	45	100	10,6	3	4	M4 x 12	4,6	0,18
GBR 12	GBR012	12	29	33,0	45	100	10,6	4	4	M4 x 12	4,6	0,18
GBR 14	GBR014	14	34	39,4	50	190	12,0	5	4	M5 x 16	9,5	0,27
GBR 15	GBR015	15	34	39,4	50	190	12,0	5	4	M5 x 16	9,5	0,27
GBR 16	GBR016	16	34	39,4	50	190	12,0	5	4	M5 x 16	9,5	0,26
GBR 20	GBR020	20	42	48,9	65	350	15,4	6	4	M6 x 16	16,0	0,52
GBR 25	GBR025	25	45	51,5	75	390	16,9	8	4	M6 x 16	16,0	0,62
GBR 30	GBR030	30	53	58,7	83	475	20,9	8	4	M6 x 18	16,0	0,92
GBR 35	GBR035	35	67	74,7	95	1100	26,7	10	4	M8 x 25	39,0	1,88
GBR 40	GBR040	40	77	84,0	108	1325	31,8	12	4	M8 x 25	39,0	2,71
GBR 50	GBR050	50	85	94,2	124	2250	34,1	14	4	M10 x 25	77,0	3,52



GIUNTI RIGIDI A DUE SEZIONI CON CHIAVETTA - BRUNITI

RIGID COUPLING TWO SPLIT BORE AND KEYWAY - BLACK OXIDE

Momenti torcenti medio elevati
 Tolleranza: albero h8
 Superficie di contatto con rugosità: R_a max 16 μm
 Montaggio e smontaggio rapido fra due alberi allineati
 Massima velocità 4000 min^{-1}
 Cave linguette secondo DIN 6885 / UNI 6604

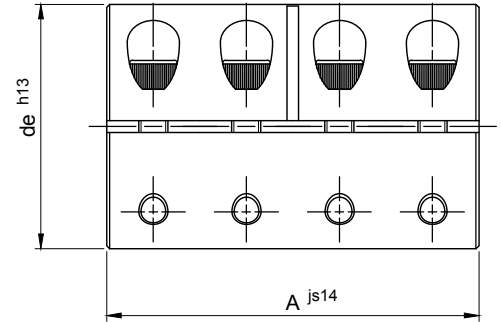
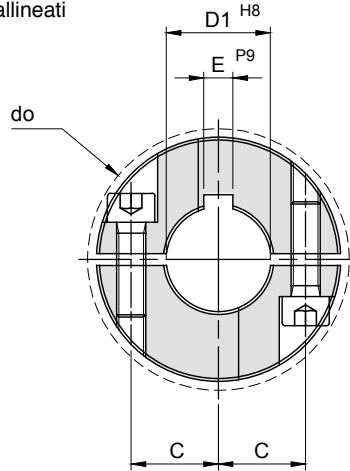

Materiale: Acciaio C-45

descrizione	codice	D1 mm	de mm	do mm	A mm	momento torcente Mt Nm	C mm	E mm	viti di serraggio				
									DIN 912 12,9		coppia di serraggio		Kg.
									N°	tipo	Ms Nm		
GBRR 6	GBRR006	6	18	21,5	30	30	5,9	2	8	M3 x 8	2,1	0,05	
GBRR 8	GBRR008	8	24	27,1	35	50	9,0	2	8	M3 x 10	2,1	0,10	
GBRR 10	GBRR010	10	29	33,0	45	100	10,6	3	8	M4 x 12	4,6	0,18	
GBRR 12	GBRR012	12	29	33,0	45	100	10,6	4	8	M4 x 12	4,6	0,18	
GBRR 14	GBRR014	14	34	39,4	50	190	12,0	5	8	M5 x 16	9,5	0,27	
GBRR 15	GBRR015	15	34	39,4	50	190	12,0	5	8	M5 x 16	9,5	0,27	
GBRR 16	GBRR016	16	34	39,4	50	190	12,0	5	8	M5 x 16	9,5	0,26	
GBRR 20	GBRR020	20	42	48,9	65	350	15,4	6	8	M6 x 16	16,0	0,52	
GBRR 25	GBRR025	25	45	51,5	75	390	16,9	8	8	M6 x 16	16,0	0,62	
GBRR 30	GBRR030	30	53	58,7	83	475	20,9	8	8	M6 x 18	16,0	0,92	
GBRR 35	GBRR035	35	67	74,7	95	1100	26,7	10	8	M8 x 25	39,0	1,88	
GBRR 40	GBRR040	40	77	84,0	108	1325	31,8	12	8	M8 x 25	39,0	2,71	
GBRR 50	GBRR050	50	85	94,2	124	2250	34,1	14	8	M10 x 25	77,0	3,52	



GIUNTI RIGIDI AD UNA SEZIONE CON CHIAVETTA - INOX

RIGID COUPLING ONE SPLIT BORE AND KEYWAY - STAINLESS STEEL

Momenti torcenti medio elevati
 Tolleranza: albero h8
 Superficie di contatto con rugosità: R_a max 16 μm
 Montaggio e smontaggio rapido fra due alberi allineati
 Massima velocità 4000 min^{-1}
 Cave linguette secondo DIN 6885 / UNI 6604

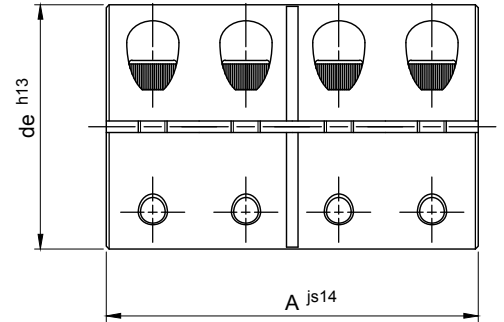
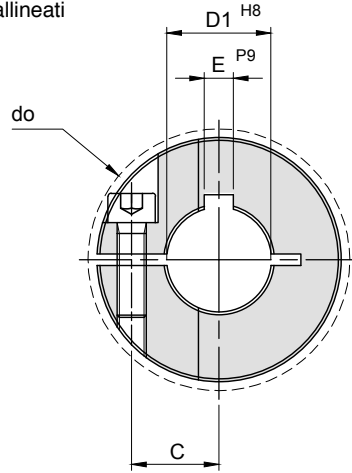

Materiale: INOX AISI 304

descrizione	codice	D1 mm	de mm	do mm	A mm	momento torcente Mt Nm	C mm	E mm	viti di serraggio			Kg.
									DIN 912 A2-70 N°	coppia di serraggio Ms Nm	tipo	
GBR 6	SSGBR006	6	18	21,5	30	25	5,9	2	4	M3 x 8	1,1	0,05
GBR 8	SSGBR008	8	24	27,1	35	40	9,0	2	4	M3 x 10	1,1	0,10
GBR 10	SSGBR010	10	29	33,0	45	90	10,6	3	4	M4 x 12	2,5	0,18
GBR 12	SSGBR012	12	29	33,0	45	90	10,6	4	4	M4 x 12	2,5	0,18
GBR 14	SSGBR014	14	34	39,4	50	160	12,0	5	4	M5 x 16	5,4	0,27
GBR 15	SSGBR015	15	34	39,4	50	160	12,0	5	4	M5 x 16	5,4	0,27
GBR 16	SSGBR016	16	34	39,4	50	160	12,0	5	4	M5 x 16	5,4	0,26
GBR 20	SSGBR020	20	42	48,9	65	300	15,4	6	4	M6 x 16	9,6	0,52
GBR 25	SSGBR025	25	45	51,5	75	325	16,9	8	4	M6 x 16	9,6	0,62
GBR 30	SSGBR030	30	53	58,7	83	400	20,9	8	4	M6 x 18	9,6	0,92
GBR 35	SSGBR035	35	67	74,7	95	925	26,7	10	4	M8 x 25	23,0	1,88
GBR 40	SSGBR040	40	77	84,0	108	1100	31,8	12	4	M8 x 25	23,0	2,71
GBR 50	SSGBR050	50	85	94,2	124	1875	34,1	14	4	M10 x 25	46,0	3,52



GIUNTI RIGIDI A DUE SEZIONI CON CHIAVETTA - INOX

RIGID COUPLING TWO SPLIT BORE AND KEYWAY - STAINLESS STEEL

Momenti torcenti medio elevati
 Tolleranza: albero h8
 Superficie di contatto con rugosità: R_a max 16 μm
 Montaggio e smontaggio rapido fra due alberi allineati
 Massima velocità 4000 min^{-1}
 Cave linguette secondo DIN 6885 / UNI 6604

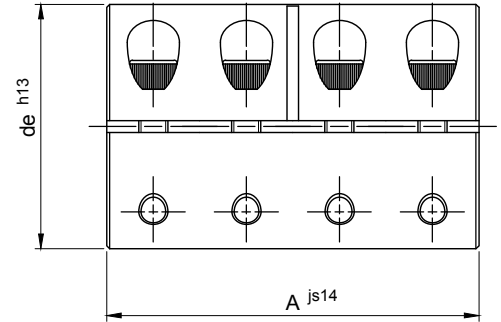
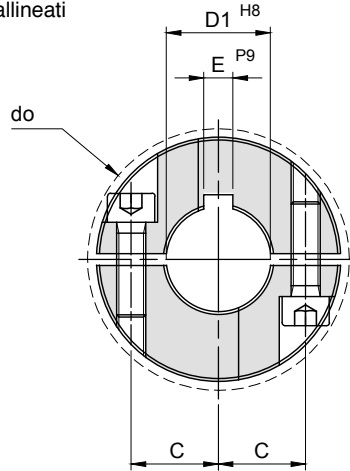

Materiale: INOX AISI 304

descrizione	codice	D1 mm	de mm	do mm	A mm	momento torcente Mt Nm	C mm	E mm	viti di serraggio			Kg.
									DIN 912 A2-70 N°	coppia di serraggio Ms Nm	tipo	
GBRR 6	SSGBRR006	6	18	21,5	30	25	5,9	2	8	M3 x 8	1,1	0,05
GBRR 8	SSGBRR008	8	24	27,1	35	40	9,0	2	8	M3 x 10	1,1	0,10
GBRR 10	SSGBRR010	10	29	33,0	45	90	10,6	3	8	M4 x 12	2,5	0,18
GBRR 12	SSGBRR012	12	29	33,0	45	90	10,6	4	8	M4 x 12	2,5	0,18
GBRR 14	SSGBRR014	14	34	39,4	50	160	12,0	5	8	M5 x 16	5,4	0,27
GBRR 15	SSGBRR015	15	34	39,4	50	160	12,0	5	8	M5 x 16	5,4	0,27
GBRR 16	SSGBRR016	16	34	39,4	50	160	12,0	5	8	M5 x 16	5,4	0,26
GBRR 20	SSGBRR020	20	42	48,9	65	300	15,4	6	8	M6 x 16	9,6	0,52
GBRR 25	SSGBRR025	25	45	51,5	75	325	16,9	8	8	M6 x 16	9,6	0,62
GBRR 30	SSGBRR030	30	53	58,7	83	400	20,9	8	8	M6 x 18	9,6	0,92
GBRR 35	SSGBRR035	35	67	74,7	95	925	26,7	10	8	M8 x 25	23,0	1,88
GBRR 40	SSGBRR040	40	77	84,0	108	1100	31,8	12	8	M8 x 25	23,0	2,71
GBRR 50	SSGBRR050	50	85	94,2	124	1875	34,1	14	8	M10 x 25	46,0	3,52