



CALETTATORI AUTOCENTRANTI "BK 10" LOCKING ASSEMBLIES SELF-CENTERING "BK 10"

Autocentrante

Momenti torcenti bassi

Tolleranze: albero h7 - mozzo H7

Superfici di contatto con rugosità: R_a max 16 μ m

Montaggio e smontaggio rapido

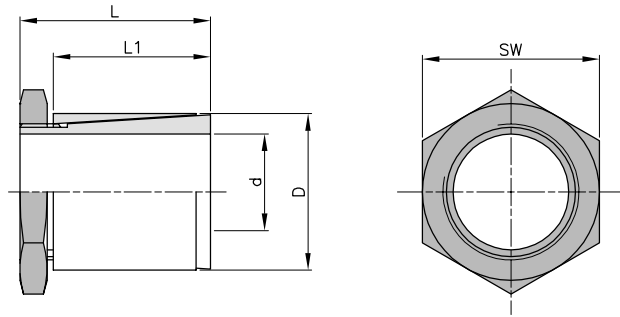

Materiale: INOX

d x D mm	codice	L mm	L1 mm	SW mm	momento torcente max Mt Nm	serraggio		Kg.
						ghiera tipo	coppia di serraggio Ms Nm	
4 x 8	BKSS010004008	15	12,5	8	3	M6x0,5	4	0,01
5 x 10	BKSS010005010	15	12,5	10	4	M8x0,5	5	0,01
6 x 10	BKSS010006010	15	12,5	10	7	M8x0,5	8	0,01
6,35 x 10	BKSS010635010	15	12,5	10	7	M8x0,5	8	0,01
7 x 12	BKSS010007012	15	12,0	12	8	M10x0,75	9	0,01
8 x 14	BKSS010008014	22	19,0	16	14	M12x1	15	0,02
9 x 14	BKSS010009014	22	19,0	16	14	M12x1	15	0,02
9,53 x 14	BKSS010953014	22	19,0	16	14	M12x1	15	0,02
10 x 17	BKSS010010017	22	18,5	18	18	M15x1	19	0,03
11 x 17	BKSS010011017	22	18,5	18	18	M15x1	19	0,03
12 x 17	BKSS010012017	22	18,5	18	18	M15x1	19	0,03
14 x 20	BKSS010014020	28	23,0	20	24	M17x1	25	0,04
15 x 20	BKSS010015020	28	23,0	20	24	M17x1	25	0,04
15,88 x 23	BKSS010158023	28	23,0	26	26	M20x1	27	0,05
16 x 23	BKSS010016023	28	23,0	26	26	M20x1	27	0,05
17 x 23	BKSS010017025	28	23,0	26	26	M20x1	27	0,05
19 x 25	BKSS010019025	28	23,0	27	29	M22x1	30	0,05
20 x 28	BKSS010020028	28	23,0	30	31	M25x1	32	0,07



CALETTATORI AUTOCENTRANTI "BK 30"

LOCKING ASSEMBLIES SELF-CENTERING "BK 30"

Autocentrante

Momenti torcenti medio bassi
 Tolleranze: albero h7 - mozzo H8
 Superfici di montaggio con rugosità: $R_t = 16 \mu\text{m}$
 Errore di concentricità: $0,02 \div 0,04 \text{ mm}$
 Montaggio e smontaggio rapido

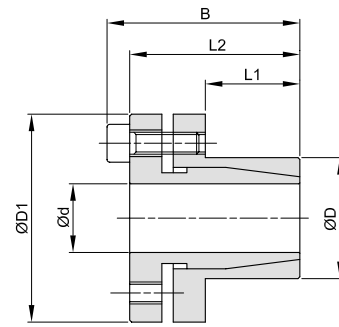
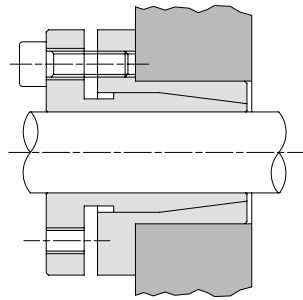

Materiale: INOX

d x D mm	codice	L1 mm	L2 mm	B mm	ØD1 mm	momento torcente Mt Nm	forza assiale F ass. KN	viti di serraggio		coppia di serraggio Ms Nm	Kg.
								DIN 912 S.S. N°	tipo		
6 x 14	BKSS030006014	10	19,0	22,0	25	5	1,7	3	M3	1,2	0,03
8 x 15	BKSS030008015	12	21,5	25,5	27	17	4,4	3	M4	2,7	0,04
10 x 16	BKSS030010016	14	24,0	28,0	28	23	4,4	3	M4	2,7	0,05
12 x 18	BKSS030012018	14	25,5	29,5	30	27	4,4	3	M4	2,7	0,06
14 x 22	BKSS030014022	15	27,5	31,5	35	48	6,5	4	M4	2,7	0,08



CALETTATORI NON AUTOCENTRANTI "BK 40"

LOCKING ASSEMBLIES NOT SELF-CENTERING "BK 40"

Non Autocentrante

Momenti torcenti medio elevati

Tolleranze: albero h11 - mozzo H11

Superfici di contatto con rugosità: R_a max 16 μ m

Smontaggio rapido

- Per ottenere una buona concentricità è necessaria una guida tra albero e mozzo

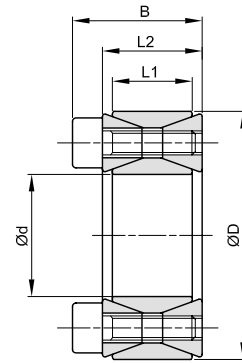
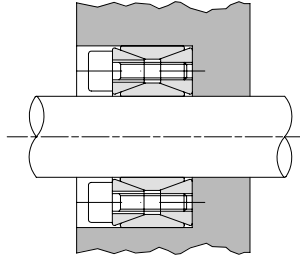

Materiale: INOX

d x D mm	codice	L1 mm	L2 mm	B mm	momento torcente Mt Nm	forza assiale F ass. KN	pressione superficiale		viti di serraggio			Kg.
							albero pw N/mm ²	mozzo pn N/mm ²	DIN 912 S.S. N°	coppia di serraggio Ms Nm	tipo	
20 x 47	BKSS040020047	17	20	26	110	11,0	133	57	8	M6x18	8	0,23
22 x 47	BKSS040022047	17	20	26	120	11,0	121	57	8	M6x18	8	0,23
24 x 50	BKSS040024050	17	20	26	150	12,0	125	60	9	M6x18	8	0,26
25 x 50	BKSS040025050	17	20	26	155	12,0	120	60	9	M6x18	8	0,25
28 x 55	BKSS040028055	17	20	26	170	12,0	107	55	9	M6x18	8	0,30
30 x 55	BKSS040030055	17	20	26	185	12,0	100	55	9	M6x18	8	0,29
32 x 60	BKSS040032060	17	20	26	265	16,0	125	66	12	M6x18	8	0,34
35 x 60	BKSS040035060	17	20	26	290	16,0	114	67	12	M6x18	8	0,32
38 x 65	BKSS040038065	17	20	26	390	20,0	131	77	15	M6x18	8	0,36
40 x 65	BKSS040040065	17	20	26	410	20,0	125	77	15	M6x18	8	0,34
42 x 75	BKSS040042075	20	24	32	595	20,0	138	78	12	M8x22	18	0,60
45 x 75	BKSS040045075	20	24	32	635	28,0	129	78	12	M8x22	18	0,57
48 x 80	BKSS040048080	20	24	32	680	28,0	121	73	12	M8x22	18	0,60
50 x 80	BKSS040050080	20	24	32	700	28,0	116	73	12	M8x22	18	0,60



CALETTATORI AUTOCENTRANTI "BK 61"

LOCKING ASSEMBLIES SELF-CENTERING "BK 61"

Autocentrante

Momenti torcenti medio elevati

Tolleranze: albero h8 - mozzo H8

Superfici di contatto con rugosità: R_a max 16 μm

Errore di concentricità: 0,02 mm \div 0,04 mm

Tempi di montaggio contenuti

☐ Durante il montaggio si può verificare un leggero spostamento assiale del mozzo rispetto all'albero

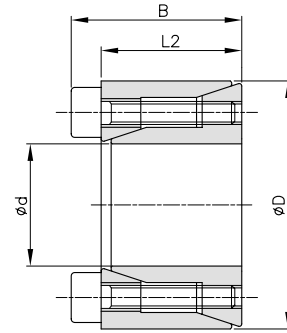
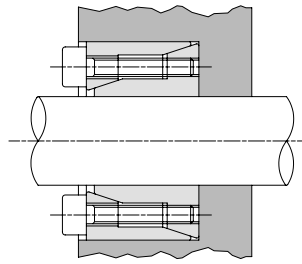

Materiale: INOX

d x D mm	codice	L2 mm	B mm	momento torcente Mt Nm	forza assiale F ass. KN	pressione superficiale		viti di serraggio			Kg.
						albero pw N/mm ²	mozzo pn N/mm ²	DIN 912 S.S. N°	coppia di serraggio Ms Nm	tipo	
6 x 16	BKSS061006016	11	13,5	3	0,9	49	19	3	M2,5x10	0,5	0,01
7 x 17	BKSS061007017	11	13,5	3	0,9	42	17	3	M2,5x10	0,5	0,01
8 x 18	BKSS061008018	11	13,5	4	0,9	37	17	3	M2,5x10	0,5	0,02
9 x 20	BKSS061009020	13	15,5	6	1,2	37	17	4	M2,5x12	0,5	0,02
10 x 20	BKSS061010020	13	15,5	6	1,2	33	17	4	M2,5x12	0,5	0,02
11 x 22	BKSS061011022	13	15,5	7	1,2	30	15	4	M2,5x12	0,5	0,02
12 x 22	BKSS061012022	13	15,5	7	1,2	26	15	4	M2,5x12	0,5	0,02
14 x 26	BKSS061014026	17	20,0	13	1,9	28	15	4	M3x16	0,9	0,04
15 x 28	BKSS061015028	17	20,0	14	1,9	26	14	4	M3x16	0,9	0,04
16 x 32	BKSS061016032	17	21,0	28	3,5	45	23	4	M4x16	2,2	0,07
17 x 35	BKSS061017035	21	25,0	30	3,5	34	17	4	M4x20	2,2	0,09
18 x 35	BKSS061018035	21	25,0	32	3,5	32	17	4	M4x20	2,2	0,09
19 x 35	BKSS061019035	21	25,0	34	3,5	31	17	4	M4x20	2,2	0,08
20 x 38	BKSS061020038	21	26,0	55	5,5	45	24	4	M5x20	4,2	0,10
22 x 40	BKSS061022040	21	26,0	61	5,5	41	23	4	M5x20	4,2	0,11
24 x 47	BKSS061024047	26	32,0	96	8,0	44	23	4	M6x24	7,3	0,20
25 x 47	BKSS061025047	26	32,0	100	8,0	43	23	4	M6x24	7,3	0,19
28 x 50	BKSS061028050	26	32,0	210	15,0	57	32	6	M6x24	7,3	0,22
30 x 55	BKSS061030055	26	32,0	220	15,0	54	29	6	M6x24	7,3	0,27
32 x 55	BKSS061032055	26	32,0	240	15,0	50	29	6	M6x24	7,3	0,25
35 x 60	BKSS061035060	29	35,0	350	20,0	55	32	6	M6x28	7,3	0,36
38 x 65	BKSS061038065	29	35,0	380	20,0	51	29	6	M6x28	7,3	0,43
40 x 65	BKSS061040065	29	35,0	400	20,0	48	29	6	M6x28	7,3	0,40



CALETTATORI AUTOCENTRANTI "BK 80"

LOCKING ASSEMBLIES SELF-CENTERING "BK 80"

Autocentrante

Momenti torcenti medio elevati
 Tolleranze: albero h8 - mozzo H8
 Superfici di contatto con rugosità: R_a max 16 μ m
 Errore di concentricità: $0,02 \pm 0,04$ mm
 Tempi di montaggio contenuti
 Ingombri radiali ristretti
 Pressioni superficiali contenute

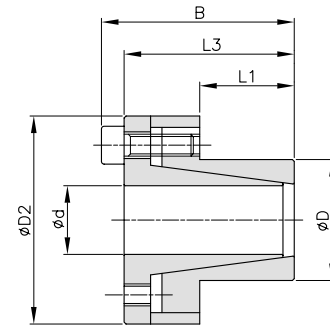
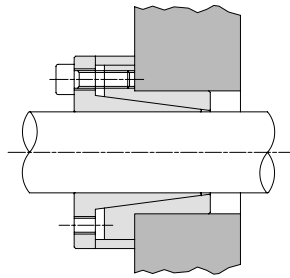

Materiale: INOX

d x D mm	codice	L1 mm	L3 mm	B mm	D2 mm	momento torcente Mt Nm	forza assiale F ass. KN	pressione superficiale		viti di serraggio			Kg.
								albero pw N/mm ²	mozzo pn N/mm ²	DIN 912 S.S. N°	coppia di serraggio Ms Nm	tipo	
10 x 16	BKSS080010016	14	27	31	29	22	4,0	82	51	4	M4x12	2	0,15
12 x 18	BKSS080012018	14	28	32	32	26	4,0	69	46	4	M4x12	2	0,18
14 x 23	BKSS080014023	14	28	32	38	30	4,0	59	36	4	M4x12	2	0,20
15 x 24	BKSS080015024	16	37	43	44	73	10,0	107	67	4	M6x18	8	0,31
16 x 24	BKSS080016024	16	37	43	44	78	10,0	101	67	3	M6x18	8	0,30
18 x 26	BKSS080018026	18	39	45	47	87	10,0	79	55	4	M6x18	8	0,32
19 x 27	BKSS080019027	18	39	45	49	92	10,0	75	53	4	M6x18	8	0,35
20 x 28	BKSS080020028	18	39	45	50	97	10,0	71	51	4	M6x18	8	0,36
22 x 32	BKSS080022032	25	46	52	54	105	10,0	47	32	4	M6x18	8	0,45
24 x 34	BKSS080024034	25	46	52	56	175	15,0	64	45	6	M6x18	8	0,48
25 x 34	BKSS080025034	25	46	52	56	180	15,0	62	45	6	M6x18	8	0,50
28 x 39	BKSS080028039	25	46	52	61	200	15,0	55	40	6	M6x18	8	0,52
30 x 41	BKSS080030041	25	46	52	62	220	15,0	51	38	6	M6x18	8	0,52
32 x 43	BKSS080032043	25	46	52	65	310	19,0	64	48	6	M6x18	8	0,58
35 x 47	BKSS080035047	32	53	59	66	340	19,0	46	34	8	M6x18	8	0,69
38 x 50	BKSS080038050	32	53	59	72	370	19,0	42	32	8	M6x18	8	0,73
40 x 53	BKSS080040053	32	53	59	75	390	19,0	40	30	8	M6x18	8	0,80
42 x 55	BKSS080042055	32	53	59	78	410	19,0	39	29	8	M6x18	8	1,05
45 x 59	BKSS080045059	45	70	78	86	820	36,0	48	36	8	M8x22	18	1,40
48 x 62	BKSS080048062	45	70	78	87	880	36,0	45	35	8	M8x22	18	1,50
50 x 65	BKSS080050065	45	70	78	92	910	36,0	43	33	8	M8x22	18	1,60