

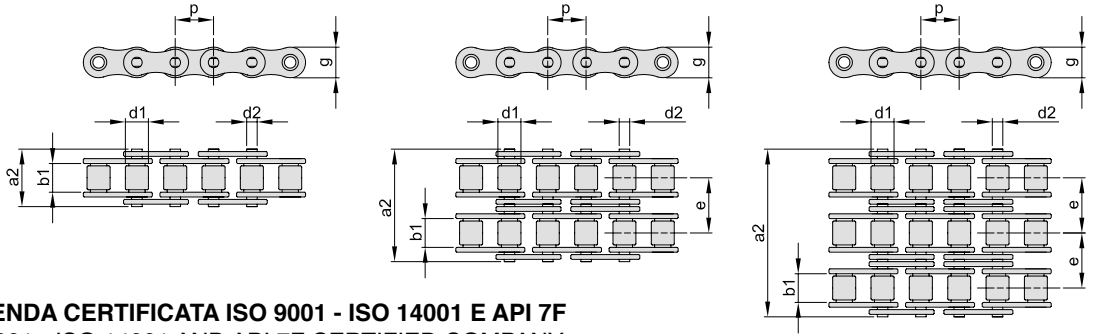

CATENE A RULLI SERIE EUROPEA - DIN 8187 - ISO 606

ROLLER CHAINS EUROPEAN STANDARD - DIN 8187 - ISO 606

Le catene a rulli serie europea possono operare a temperature da -10° a +150°



CATENA PRODOTTA DA AZIENDA CERTIFICATA ISO 9001 - ISO 14001 E API 7F
CHAIN PRODUCED BY ISO 9001 - ISO 14001 AND API 7F CERTIFIED COMPANY

CATENA PRESTIRATA / PRE-STRETCHED CHAINS

CONFEZIONI DA 5 MT - ROTOLI DA ▲ 50 MT - ROTOLI DA ■ 100 MT



SEMPLICE

ISO	codice	p		b ₁ mm min.	d ₂ mm	d ₁ mm max.	a ₂ mm max.	g mm max.	Carico di rottura		q kg/m ≈
		mm	inch						minimo KN	medio KN	
04-1	600106000	6	-	2,80	1,85	4,00	7,4	5,00	3,0	3,3	0,12
05B-1	600108000	8	-	3,00	2,31	5,00	8,6	7,11	5,0	5,9	0,18
06B-1	600109000	9,525	3/8"	5,72	3,28	6,35	13,5	8,26	9,0	10,7	0,40
06B-1 ■	600109075	9,525	3/8"	5,72	3,28	6,35	13,5	8,26	9,0	10,7	0,40
08B-1	600112000	12,7	1/2"	7,75	4,45	8,51	17,0	11,81	18,0	21,1	0,68
08B-1 ▲	600112050	12,7	1/2"	7,75	4,45	8,51	17,0	11,81	18,0	21,1	0,68
10B-1	600115000	15,875	5/8"	9,65	5,08	10,16	19,6	14,73	22,4	27,4	0,91
10B-1 ▲	600115050	15,875	5/8"	9,65	5,08	10,16	19,6	14,73	22,4	27,4	0,91
12B-1	600119000	19,05	3/4"	11,68	5,72	12,07	22,7	16,13	29,0	32,3	1,12
12B-1 ▲	600119050	19,05	3/4"	11,68	5,72	12,07	22,7	16,13	29,0	32,3	1,12
16B-1	600125000	25,4	1"	17,02	8,28	15,88	36,1	21,08	60,0	70,6	2,59
20B-1	600131000	31,75	1 1/4"	19,56	10,19	19,05	43,2	26,42	95,0	109,8	3,68
24B-1	600138000	38,1	1 1/2"	25,40	14,63	25,40	53,4	33,40	160,0	179,0	6,85
28B-1	600144000	44,45	1 3/4"	30,99	15,90	27,94	65,1	37,08	200,0	226,0	8,56
32B-1	600150000	50,8	2"	30,99	17,81	29,21	67,4	42,29	250,0	273,0	9,49
40B-1	600163000	63,5	2 1/2"	38,10	22,89	39,37	82,6	52,90	355,0	390,0	15,53

DOPPIA

ISO	codice	p		b ₁ mm min.	d ₂ mm	d ₁ mm max.	a ₂ mm max.	g mm max.	e mm	Carico di rottura		q kg/m ≈
		mm	inch							minimo KN	medio KN	
05B-2	600108200	8	-	3,00	2,31	5,00	14,3	7,11	5,64	7,8	8,5	0,32
06B-2	600109200	9,525	3/8"	5,72	3,28	6,35	23,8	8,26	10,24	16,9	19,2	0,76
08B-2	600112200	12,7	1/2"	7,75	4,45	8,51	31,0	11,81	13,92	32,0	38,0	1,31
10B-2	600115200	15,875	5/8"	9,65	5,08	10,16	36,2	14,73	16,59	44,5	57,3	1,79
12B-2	600119200	19,05	3/4"	11,68	5,72	12,07	42,2	16,13	19,46	57,8	65,7	2,22
16B-2	600125200	25,4	1"	17,02	8,28	15,88	68,0	21,08	31,88	113,7	137,5	5,03
20B-2	600131200	31,75	1 1/4"	19,56	10,19	19,05	79,7	26,42	36,45	170,0	210,0	7,33
24B-2	600138200	38,1	1 1/2"	25,40	14,63	25,40	101,8	33,40	48,36	280,0	322,5	13,50
28B-2	600144200	44,45	1 3/4"	30,99	15,90	27,94	124,7	37,08	59,56	360,0	412,6	16,96
32B-2	600150200	50,8	2"	30,99	17,81	29,21	126,0	42,99	58,55	450,0	510,8	18,74
40B-2	600163200	63,5	2 1/2"	38,10	22,89	39,37	154,0	52,90	72,29	630,0	708,1	30,72

TRIPLA

ISO	codice	p		b ₁ mm min.	d ₂ mm	d ₁ mm max.	a ₂ mm max.	g mm max.	e mm	Carico di rottura		q kg/m ≈
		mm	inch							minimo KN	medio KN	
06B-3	600109300	9,525	3/8"	5,72	3,28	6,35	34,0	8,26	10,24	24,9	27,7	1,12
08B-3	600112300	12,7	1/2"	7,75	4,45	8,51	44,9	11,81	13,92	47,5	56,0	1,94
10B-3	600115300	15,875	5/8"	9,65	5,08	10,16	52,8	14,73	16,59	66,7	83,3	2,68
12B-3	600119300	19,05	3/4"	11,68	5,72	12,07	61,7	16,13	19,46	86,7	101,5	3,32
16B-3	600125300	25,4	1"	17,02	8,28	15,88	99,9	21,08	31,88	160,0	202,8	7,65
20B-3	600131300	31,75	1 1/4"	19,56	10,19	19,05	116,1	26,42	36,45	250,0	306,5	10,96
24B-3	600138300	38,1	1 1/2"	25,40	14,63	25,40	150,2	33,40	48,36	425,0	490,6	20,20
28B-3	600144300	44,45	1 3/4"	30,99	15,90	27,94	184,3	37,08	59,56	530,0	625,9	25,38
32B-3	600150300	50,8	2"	30,99	17,81	29,21	184,5	42,99	58,55	670,0	775,0	28,04



CATENE A RULLI SERIE AMERICANA - DIN 8188 - ANSI B29.1 "ASA" ROLLER CHAINS AMERICAN STANDARD - DIN 8188 - ANSI B29.1 "ASA"

Le catene a rulli serie americana possono operare a temperature da -10° a +150°

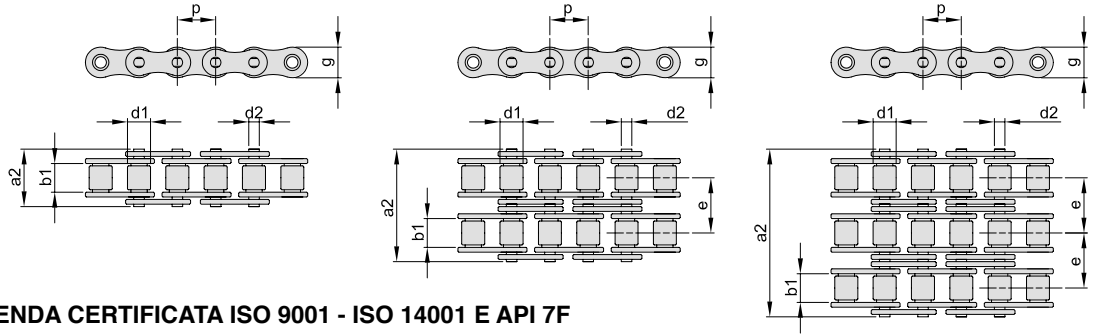

CATENA PRODOTTA DA AZIENDA CERTIFICATA ISO 9001 - ISO 14001 E API 7F
CHAIN PRODUCED BY ISO 9001 - ISO 14001 AND API 7F CERTIFIED COMPANY

CATENA PRESTIRATA / PRE-STRETCHED CHAINS

CONFEZIONI DA 3 MT



SEMPLICE

ANSI	codice	p		b ₁ mm min.	d ₂ mm	d ₁ mm max.	a ₂ mm max.	g mm max.	Carico di rottura		q kg/m ≈
		mm	inch						minimo KN	medio KN	
35-1	620035000	9,525	3/8"	4,77	3,58	5,08	13,2	9,05	7,8	10,1	0,34
40-1	620040000	12,7	1/2"	7,95	3,96	7,92	17,8	12,07	14,1	18,8	0,63
50-1	620050000	15,875	5/8"	9,53	5,08	10,16	21,8	15,09	22,2	30,4	1,04
60-1	620060000	19,05	3/4"	12,70	5,94	11,91	26,9	18,08	31,8	41,7	1,52
80-1	620080000	25,4	1"	15,88	7,92	15,88	33,5	24,13	56,7	72,6	2,58
100-1	620100000	31,75	1 1/4"	19,05	9,53	19,05	41,1	30,18	88,5	110,4	3,85
120-1	620120000	38,1	1 1/2"	25,40	11,10	22,23	50,8	36,20	127,0	144,6	5,61
140-1	620140000	44,45	1 3/4"	25,40	12,70	25,40	54,9	42,24	172,4	190,8	7,24
160-1	620160000	50,8	2"	31,75	14,27	28,58	65,5	48,26	226,8	253,4	9,91
60-1H	621060000	19,05	3/4"	12,70	5,94	11,91	31,2	18,08	31,2	42,1	1,81
80-1H	621080000	25,4	1"	15,88	7,92	15,88	38,0	24,13	55,6	72,6	3,00
100-1H	621100000	31,75	1 1/4"	19,05	9,53	19,05	45,4	30,18	86,8	110,4	4,38

DOPPIA

ANSI	codice	p		b ₁ mm min.	d ₂ mm	d ₁ mm max.	a ₂ mm max.	g mm max.	e mm	Carico di rottura		q kg/m ≈
		mm	inch							minimo KN	medio KN	
35-2	620035200	9,525	3/8"	4,77	3,58	5,08	21,6	9,05	10,13	15,6	20,3	0,67
40-2	620040200	12,7	1/2"	7,95	3,96	7,92	32,3	12,07	14,38	28,2	37,7	1,26
50-2	620050200	15,875	5/8"	9,53	5,08	10,16	39,9	15,09	18,11	44,4	60,8	2,05
60-2	620060200	19,05	3/4"	12,70	5,94	11,91	49,8	18,08	22,78	63,3	83,4	3,01
80-2	620080200	25,4	1"	15,88	7,92	15,88	62,7	24,13	29,29	113,4	145,1	5,13
100-2	620100200	31,75	1 1/4"	19,05	9,53	19,05	77,0	30,18	35,76	177,0	220,8	7,64
120-2	620120200	38,1	1 1/2"	25,40	11,10	22,23	96,3	36,20	45,44	254,0	289,3	11,13
140-2	620140200	44,45	1 3/4"	25,40	12,70	25,40	103,6	42,24	48,87	344,8	381,6	14,37
160-2	620160200	50,8	2"	31,75	14,27	28,58	124,2	48,26	58,55	453,6	506,7	19,68

TRIPLA

ANSI	codice	p		b ₁ mm min.	d ₂ mm	d ₁ mm max.	a ₂ mm max.	g mm max.	e mm	Carico di rottura		q kg/m ≈
		mm	inch							minimo KN	medio KN	
*35-3	620035300	9,525	3/8"	4,77	3,58	5,08	31,8	9,05	10,13	23,4	30,5	0,99
*40-3	620040300	12,7	1/2"	7,95	3,96	7,92	46,7	12,07	14,38	42,3	56,6	1,98
*50-3	620050300	15,875	5/8"	9,53	5,08	10,16	57,9	15,09	18,11	66,6	82,5	3,06
*60-3	620060300	19,05	3/4"	12,70	5,94	11,91	72,6	18,08	22,78	95,4	120,1	4,50
*80-3	620080300	25,4	1"	15,88	7,92	15,88	91,7	24,13	29,29	170,1	201,9	7,67
*100-3	620100300	31,75	1 1/4"	19,05	9,53	19,05	113,0	30,18	35,76	265,5	313,9	11,43
*120-3	620120300	38,1	1 1/2"	25,40	11,10	22,23	141,7	36,20	45,44	381,0	433,9	16,67
*140-3	620140300	44,45	1 3/4"	25,40	12,70	25,40	152,4	42,24	48,87	517,2	583,4	21,51
*160-3	620160300	50,8	2"	31,75	14,27	28,58	182,9	48,26	58,55	680,4	760,1	29,45

* Costruite a richiesta / Manufactured on request



CATENE A RULLI CON PIASTRE A PROFILO DIRITTO - DIN 8187 - ISO 606

ROLLER CHAINS WITH STRAIGHT PLATES - DIN 8187 - ISO 606

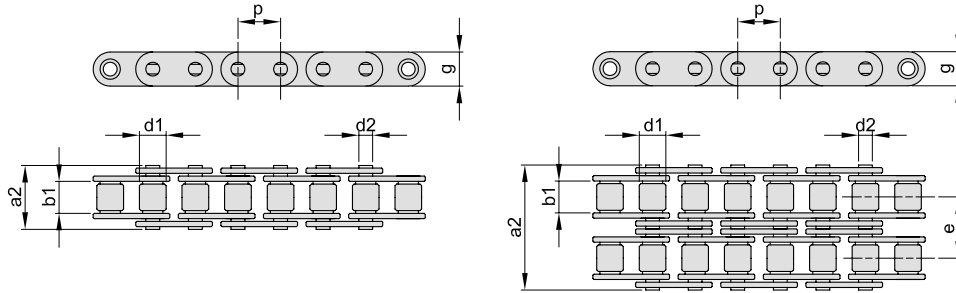

CATENA PRODOTTA DA AZIENDA CERTIFICATA ISO 9001 - ISO 14001 E API 7F
CHAIN PRODUCED BY ISO 9001 - ISO 14001 AND API 7F CERTIFIED COMPANY

CATENA PRESTIRATA / PRE-STRETCHED CHAINS



CONFEZIONI DA 5 MT

SEMPLICE

ISO	codice	p		b ₁ mm min.	d ₂ mm	d ₁ mm max.	a ₂ mm max.	g mm max.	Carico di rottura		q kg/m ≈
		mm	inch						minimo KN	medio KN	
08B-1	601112000	12,7	1/2"	7,75	4,45	8,51	17,0	11,8	18,0	21,1	0,75
10B-1	601115000	15,875	5/8"	9,65	5,08	10,16	19,6	14,7	22,4	27,4	0,98
12B-1	601119000	19,05	3/4"	11,68	5,72	12,07	22,7	16,1	29,0	32,3	1,24
16B-1	601125000	25,4	1"	17,02	8,28	15,88	36,1	20,6	60,0	70,6	3,30
20B-1	601131000	31,75	1" 1/4	19,56	10,19	19,05	43,2	26,4	95,0	109,8	3,91

DOPPIA

ISO	codice	p		b ₁ mm min.	d ₂ mm	d ₁ mm max.	a ₂ mm max.	g mm max.	e mm	Carico di rottura		q kg/m ≈
		mm	inch							minimo KN	medio KN	
10B-2	601115200	15,875	5/8"	9,65	5,08	10,16	36,2	14,7	16,59	44,5	57,3	1,97
12B-2	601119200	19,05	3/4"	11,68	5,72	12,07	42,2	16,1	19,46	57,8	65,7	2,27
16B-2	601125200	25,4	1"	17,02	8,28	15,88	68,0	20,6	31,88	113,7	137,5	5,78
20B-2	601131200	31,75	1" 1/4	19,56	10,19	19,05	79,7	26,4	35,45	170,0	210,0	7,72



CATENE A PERNI FORATI - DIN 8187 - ISO 606

HOLLOW PINS CHAINS - DIN 8187 - ISO 606

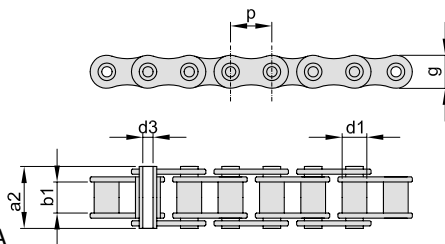

TIPO A - A BUSSOLA

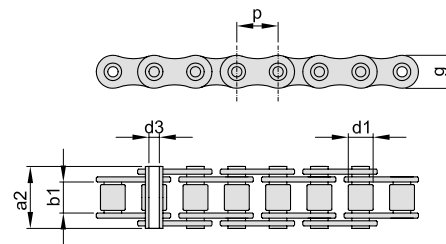

TIPO B - A RULLI

CATENA PRODOTTA DA AZIENDA CERTIFICATA ISO 9001 - ISO 14001 E API 7F
CHAIN PRODUCED BY ISO 9001 - ISO 14001 AND API 7F CERTIFIED COMPANY

CATENA PRESTIRATA / PRE-STRETCHED CHAINS



CONFEZIONI DA 5 MT

ISO	codice	p		b ₁ mm min.	d ₃ mm	d ₁ mm max.	a ₂ mm max.	g mm max.	Carico di rottura		q kg/m ≈	TIPO
		mm	inch						minimo KN	medio KN		
08B-1	601512000	12,7	1/2"	7,75	4,50	8,51	17,0	11,6	9,3	12,8	0,58	A
10B-1	601515000	15,875	5/8"	9,65	5,18	10,16	19,6	14,7	12,7	16,4	0,73	A
12B-1	601519000	19,05	3/4"	11,68	5,85	12,07	22,7	15,9	12,7	17,5	1,10	A
08B-1	601612000	12,7	1/2"	7,75	4,50	8,51	17,0	11,6	10,8	17,4	0,58	B
10B-1	601615000	15,875	5/8"	9,65	5,18	10,16	19,6	14,5	14,7	19,7	0,77	B
12B-1	601619000	19,05	3/4"	11,68	5,85	12,07	22,7	15,9	16,7	23,3	0,98	B
16B-1	601625000	25,4	1"	17,02	8,33	15,88	36,1	20,5	32,7	41,0	2,21	B



CATENE A RULLI AUTOLUBRIFICANTI - DIN 8187 - ISO 606

SINTERED BUSH CHAINS - DIN 8187 - ISO 606

Costruita con speciali bussole in acciaio sinterizzato. Indicata per applicazioni con scarsa lubrificazione come nelle industrie alimentari, chimiche, farmaceutiche, elettroniche ecc.

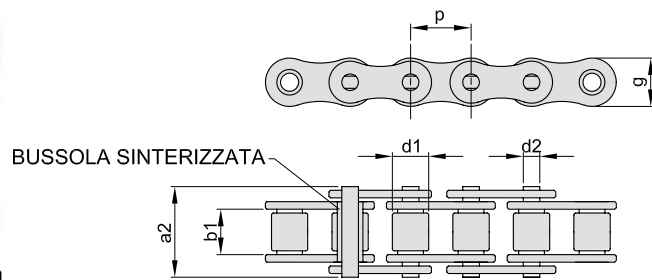
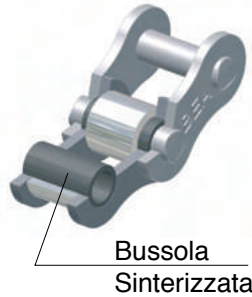

CATENA PRODOTTA DA AZIENDA CERTIFICATA ISO 9001 - ISO 14001 E API 7F
CHAIN PRODUCED BY ISO 9001 - ISO 14001 AND API 7F CERTIFIED COMPANY

CATENA PRESTIRATA / PRE-STRETCHED CHAINS

CONFEZIONI DA 5 MT



ISO	codice	p		b ₁ mm min.	d ₂ mm	d ₁ mm max.	a ₂ mm max.	g mm max.	Carico di rottura		q kg/m ≈
		mm	inch						minimo KN	medio KN	
08B-1	643112000	12,7	1/2"	7,75	4,45	8,51	17,0	12,40	18,0	19,6	0,70
10B-1	643115000	15,875	5/8"	9,65	5,08	10,16	19,6	14,70	22,4	25,7	0,88
12B-1	643119000	19,05	3/4"	11,68	5,72	12,07	22,7	16,10	29,0	30,4	1,10



CATENE A RULLI "O-RING" - DIN 8187 - ISO 606

"O-RING" CHAINS - DIN 8187 - ISO 606

Costruita con anelli di tenuta lubrificati che impediscono l'entrata di detriti e offrono una maggiore resistenza all'usura. Le catene a rulli O-RING possono operare a temperature da -10° a +60°

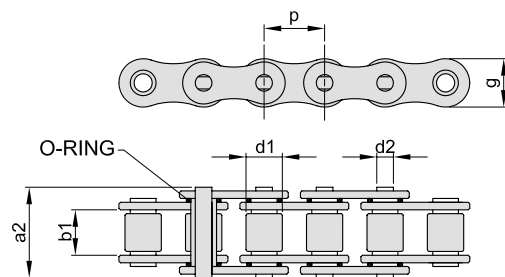
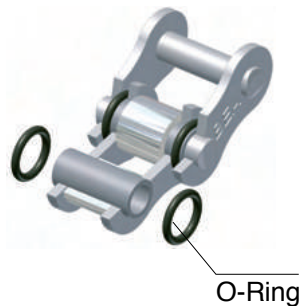

CATENA PRODOTTA DA AZIENDA CERTIFICATA ISO 9001 - ISO 14001 E API 7F
CHAIN PRODUCED BY ISO 9001 - ISO 14001 AND API 7F CERTIFIED COMPANY

CATENA PRESTIRATA / PRE-STRETCHED CHAINS

CONFEZIONE DA 5 MT

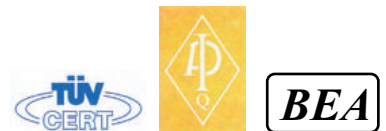

ISO	codice	p		b ₁ mm min.	d ₂ mm	d ₁ mm max.	a ₂ mm max.	g mm max.	Carico di rottura		q kg/m ≈
		mm	inch						minimo KN	medio KN	
08B-1	644112000	12,7	1/2"	7,75	4,45	8,51	19,0	11,56	18,1	18,4	0,70
10B-1	644115000	15,875	5/8"	9,65	5,06	10,16	21,9	14,48	22,2	23,8	0,92



CATENE A RULLI CON ATTACCHI ANGOLARI - DIN 8187 - ISO 606

ROLLER CHAINS WITH ANGLE ATTACHMENTS - DIN 8187 - ISO 606

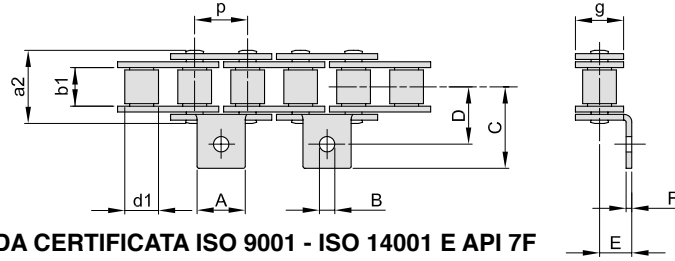

A1/02

CATENA PRODOTTA DA AZIENDA CERTIFICATA ISO 9001 - ISO 14001 E API 7F
CHAIN PRODUCED BY ISO 9001 - ISO 14001 AND API 7F CERTIFIED COMPANY

CATENA PRESTIRATA / PRE-STRETCHED CHAINS

CONFEZIONE DA 5 MT



ISO	codice	p		b1 mm min.	d1 mm max.	a2 mm max.	g mm max.	A mm	B mm	C mm max.	D mm	E mm	F mm	Carico di rottura		q kg/m ≈
		mm	inch											minimo KN	medio KN	
06B-1	604109112	9,525	3/8"	5,72	6,35	13,5	8,26	8,0	3,5	13,5	9,5	6,5	1,03	9,0	10,7	0,46
08B-1	604112112	12,7	1/2"	7,75	8,51	17,0	11,81	9,5	4,3	18,6	14,1	8,4	1,40	18,0	21,1	0,77
10B-1	604115112	15,875	5/8"	9,65	10,16	19,6	14,73	14,1	5,2	23,8	15,9	10,4	1,63	22,4	27,4	1,04
12B-1	604119112	19,05	3/4"	11,68	12,07	22,7	16,13	15,8	5,6	25,8	17,5	12,0	1,80	29,0	32,3	1,35
16B-1	604125112	25,4	1"	17,02	15,88	36,1	21,08	19,0	6,8	37,4	25,4	15,9	3,00	60,0	70,6	2,83

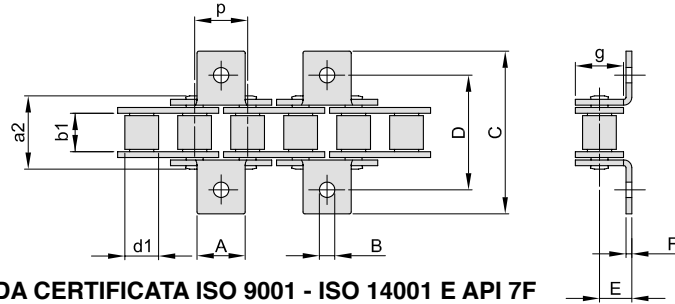

K1/02

CATENA PRODOTTA DA AZIENDA CERTIFICATA ISO 9001 - ISO 14001 E API 7F
CHAIN PRODUCED BY ISO 9001 - ISO 14001 AND API 7F CERTIFIED COMPANY

CATENA PRESTIRATA / PRE-STRETCHED CHAINS

CONFEZIONE DA 5 MT



ISO	codice	p		b1 mm min.	d1 mm max.	a2 mm max.	g mm max.	A mm	B mm	C mm max.	D mm	E mm	F mm	Carico di rottura		q kg/m ≈
		mm	inch											minimo KN	medio KN	
06B-1	604109212	9,525	3/8"	5,72	6,35	13,5	8,26	8,0	3,5	27,0	19,0	6,5	1,03	9,0	10,7	0,51
08B-1	604112212	12,7	1/2"	7,75	8,51	17,0	11,81	9,5	4,3	37,2	28,2	8,4	1,40	18,0	21,1	0,85
10B-1	604115212	15,875	5/8"	9,65	10,16	19,6	14,73	14,1	5,2	47,6	31,8	10,4	1,63	22,4	27,4	1,13
12B-1	604119212	19,05	3/4"	11,68	12,07	22,7	16,13	15,8	5,6	51,6	35,0	12,0	1,80	29,0	32,3	1,45
16B-1	604125212	25,4	1"	17,02	15,88	36,1	21,08	19,0	6,8	74,8	50,8	15,9	3,00	60,0	70,6	3,48

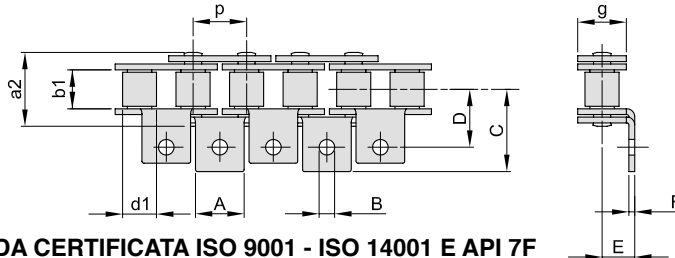

A1/01

CATENA PRODOTTA DA AZIENDA CERTIFICATA ISO 9001 - ISO 14001 E API 7F
CHAIN PRODUCED BY ISO 9001 - ISO 14001 AND API 7F CERTIFIED COMPANY

CATENA PRESTIRATA / PRE-STRETCHED CHAINS

CONFEZIONE DA 5 MT



ISO	codice	p		b1 mm min.	d1 mm max.	a2 mm max.	g mm max.	A mm	B mm	C mm max.	D mm	E mm	F mm	Carico di rottura		q kg/m ≈
		mm	inch											minimo KN	medio KN	
06B-1	604109111	9,525	3/8"	5,72	6,35	13,5	8,26	8,0	3,5	13,5	9,5	6,5	1,03	9,0	10,7	0,51
08B-1	604112111	12,7	1/2"	7,75	8,51	17,0	11,81	9,5	4,3	18,6	14,1	8,4	1,40	18,0	21,1	0,85
10B-1	604115111	15,875	5/8"	9,65	10,16	19,6	14,73	14,1	5,2	23,8	15,9	10,4	1,63	22,4	27,4	1,13
12B-1	604119111	19,05	3/4"	11,68	12,07	22,7	16,13	15,8	5,6	25,8	17,5	12,0	1,80	29,0	32,3	1,45
16B-1	604125111	25,4	1"	17,02	15,88	36,1	21,08	19,0	6,8	37,4	25,4	15,9	3,00	60,0	70,6	3,48



CATENE A RULLI CON ATTACCHI ANGOLARI - DIN 8187 - ISO 606

ROLLER CHAINS WITH ANGLE ATTACHMENTS - DIN 8187 - ISO 606

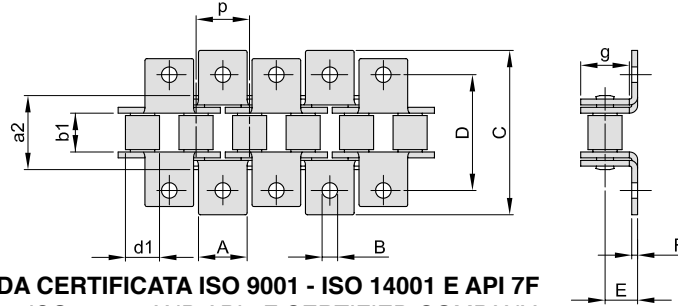

K1/01

CATENA PRODotta DA AZIENDA CERTIFICATA ISO 9001 - ISO 14001 E API 7F
CHAIN PRODUCED BY ISO 9001 - ISO 14001 AND API 7F CERTIFIED COMPANY
CATENA PRESTIRATA / PRE-STRETCHED CHAINS

CONFEZIONE DA 5 MT



ISO	codice	p		b ₁ mm min.	d ₁ mm max.	a ₂ mm max.	g mm max.	A mm	B mm	C mm max.	D mm	E mm	F mm	Carico di rottura		q kg/m ≈
		mm	inch											minimo KN	medio KN	
06B-1	604109211	9,525	3/8"	5,72	6,35	13,5	8,26	8,0	3,5	27,0	19,0	6,5	1,03	9,0	10,7	0,61
08B-1	604112211	12,7	1/2"	7,75	8,51	17,0	11,81	9,5	4,3	37,2	28,2	8,4	1,40	18,0	21,1	1,01
10B-1	604115211	15,875	5/8"	9,65	10,16	19,6	14,73	14,1	5,2	47,6	31,8	10,4	1,63	22,4	27,4	1,32
12B-1	604119211	19,05	3/4"	11,68	12,07	22,7	16,13	15,8	5,6	51,6	35,0	12,0	1,80	29,0	32,3	1,66
16B-1	604125211	25,4	1"	17,02	15,88	36,1	21,08	19,0	6,8	74,8	50,8	15,9	3,00	60,0	70,6	4,27

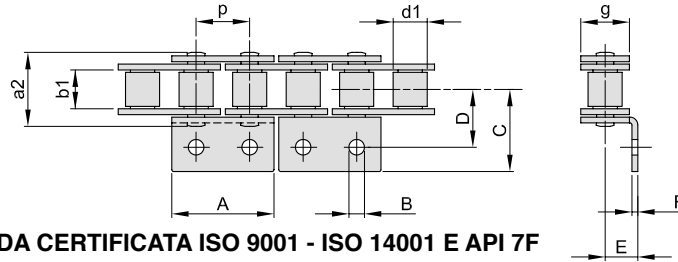

A2/02

CATENA PRODotta DA AZIENDA CERTIFICATA ISO 9001 - ISO 14001 E API 7F
CHAIN PRODUCED BY ISO 9001 - ISO 14001 AND API 7F CERTIFIED COMPANY
CATENA PRESTIRATA / PRE-STRETCHED CHAINS

CONFEZIONE DA 5 MT



ISO	codice	p		b ₁ mm min.	d ₁ mm max.	a ₂ mm max.	g mm max.	A mm	B mm	C mm max.	D mm	E mm	F mm	Carico di rottura		q kg/m ≈
		mm	inch											minimo KN	medio KN	
06B-1	604109122	9,525	3/8"	5,72	6,35	13,5	8,26	17,6	3,5	13,5	9,5	6,5	1,03	9,0	10,7	0,51
08B-1	604112122	12,7	1/2"	7,75	8,51	17,0	11,81	23,2	4,3	18,6	14,1	8,4	1,40	18,0	21,1	0,85
10B-1	604115122	15,875	5/8"	9,65	10,16	19,6	14,73	29,3	5,2	23,8	15,9	10,4	1,63	22,4	27,4	1,13
12B-1	604119122	19,05	3/4"	11,68	12,07	22,7	16,13	33,0	5,6	30,5	17,5	12,0	1,80	29,0	32,3	1,45
16B-1	604125122	25,4	1"	17,02	15,88	36,1	21,08	46,0	6,8	39,1	25,4	15,9	3,00	60,0	70,6	3,19

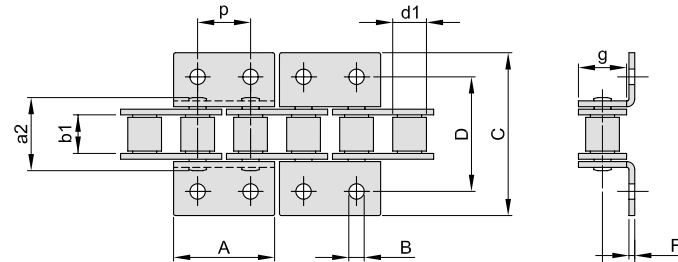

K2/02

CATENA PRODotta DA AZIENDA CERTIFICATA ISO 9001 - ISO 14001 E API 7F
CHAIN PRODUCED BY ISO 9001 - ISO 14001 AND API 7F CERTIFIED COMPANY
CATENA PRESTIRATA / PRE-STRETCHED CHAINS

CONFEZIONE DA 5 MT



ISO	codice	p		b ₁ mm min.	d ₁ mm max.	a ₂ mm max.	g mm max.	A mm	B mm	C mm max.	D mm	E mm	F mm	Carico di rottura		q kg/m ≈
		mm	inch											minimo KN	medio KN	
06B-1	604109222	9,525	3/8"	5,72	6,35	13,5	8,26	17,6	3,5	27,0	19	6,5	1,03	9,0	10,7	0,61
08B-1	604112222	12,7	1/2"	7,75	8,51	17,0	11,81	23,2	4,3	37,2	28,2	8,4	1,40	18,0	21,1	1,01
10B-1	604115222	15,875	5/8"	9,65	10,16	19,6	14,73	29,3	5,2	47,6	31,8	10,4	1,63	22,4	27,4	1,32
12B-1	604119222	19,05	3/4"	11,68	12,07	22,7	16,13	33,0	5,6	61,0	35,0	12,0	1,80	29,0	32,3	1,66
16B-1	604125222	25,4	1"	17,02	15,88	36,1	21,08	46,0	6,8	78,2	50,8	15,9	3,00	60,0	70,6	3,78



CATENE A RULLI CON ATTACCHI VERTICALI - DIN 8187 - ISO 606

ROLLER CHAINS WITH VERTICAL ATTACHMENTS - DIN 8187 - ISO 606

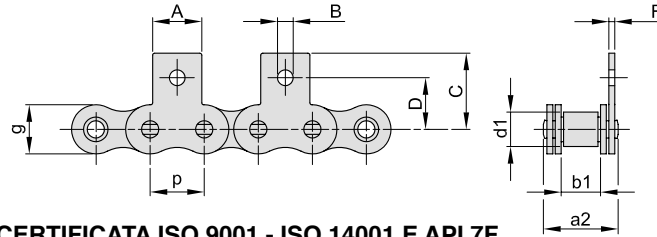

M1/02

CATENA PRODotta DA AZIENDA CERTIFICATA ISO 9001 - ISO 14001 E API 7F
CHAIN PRODUCED BY ISO 9001 - ISO 14001 AND API 7F CERTIFIED COMPANY

CATENA PRESTIRATA / PRE-STRETCHED CHAINS

CONFEZIONE DA 5 MT



ISO	codice	p		b ₁ mm min.	d ₁ mm max.	a ₂ mm max.	g mm max.	A mm	B mm	C mm max.	D mm	F mm	Carico di rottura		q kg/m ≈
		mm	inch										minimo KN	medio KN	
06B-1	603109112	9,525	3/8"	5,72	6,35	13,5	8,26	8,0	3,5	13,5	9,5	1,03	9,0	10,7	0,46
08B-1	603112112	12,7	1/2"	7,75	8,51	17,0	11,81	9,5	4,3	18,4	14,1	1,40	18,0	21,1	0,77
10B-1	603115112	15,875	5/8"	9,65	10,16	19,6	14,73	14,1	5,2	24,7	15,9	1,63	22,4	27,4	1,04
12B-1	603119112	19,05	3/4"	11,68	12,07	22,7	16,13	15,8	5,6	26,6	17,9	1,80	29,0	32,3	1,35
16B-1	603125112	25,4	1"	17,02	15,88	36,1	21,08	19,0	6,8	35,0	26,0	3,00	60,0	70,6	2,83

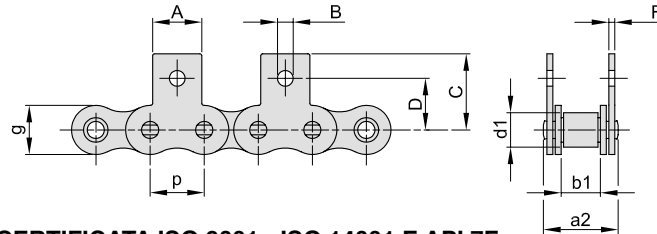

MK1/02

CATENA PRODotta DA AZIENDA CERTIFICATA ISO 9001 - ISO 14001 E API 7F
CHAIN PRODUCED BY ISO 9001 - ISO 14001 AND API 7F CERTIFIED COMPANY

CATENA PRESTIRATA / PRE-STRETCHED CHAINS

CONFEZIONE DA 5 MT



ISO	codice	p		b ₁ mm min.	d ₁ mm max.	a ₂ mm max.	g mm max.	A mm	B mm	C mm max.	D mm	F mm	Carico di rottura		q kg/m ≈
		mm	inch										minimo KN	medio KN	
06B-1	603109212	9,525	3/8"	5,72	6,35	13,5	8,26	8,0	3,5	13,5	9,5	1,03	9,0	10,7	0,51
08B-1	603112212	12,7	1/2"	7,75	8,51	17,0	11,81	9,5	4,3	18,4	14,1	1,40	18,0	21,1	0,85
10B-1	603115212	15,875	5/8"	9,65	10,16	19,6	14,73	14,1	5,2	24,7	15,9	1,63	22,4	27,4	1,13
12B-1	603119212	19,05	3/4"	11,68	12,07	22,7	16,13	15,8	5,6	26,6	17,9	1,80	29,0	32,3	1,45
16B-1	603125212	25,4	1"	17,02	15,88	36,1	21,08	19,0	6,8	35,0	26,0	3,00	60,0	70,6	3,48

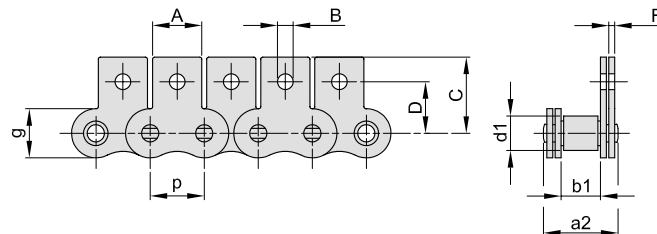

M1/01

CATENA PRODotta DA AZIENDA CERTIFICATA ISO 9001 - ISO 14001 E API 7F
CHAIN PRODUCED BY ISO 9001 - ISO 14001 AND API 7F CERTIFIED COMPANY

CATENA PRESTIRATA / PRE-STRETCHED CHAINS

CONFEZIONE DA 5 MT



ISO	codice	p		b ₁ mm min.	d ₁ mm max.	a ₂ mm max.	g mm max.	A mm	B mm	C mm max.	D mm	F mm	Carico di rottura		q kg/m ≈
		mm	inch										minimo KN	medio KN	
06B-1	603109111	9,525	3/8"	5,72	6,35	13,5	8,26	8,0	3,5	13,5	9,5	1,03	9,0	10,7	0,51
08B-1	603112111	12,7	1/2"	7,75	8,51	17,0	11,81	9,5	4,3	18,4	14,1	1,40	18,0	21,1	0,85
10B-1	603115111	15,875	5/8"	9,65	10,16	19,6	14,73	14,1	5,2	24,7	15,9	1,63	22,4	27,4	1,13
12B-1	603119111	19,05	3/4"	11,68	12,07	22,7	16,13	15,8	5,6	26,6	17,9	1,80	29,0	32,3	1,45
16B-1	603125111	25,4	1"	17,02	15,88	36,1	21,08	19,0	6,8	35,0	26,0	3,00	60,0	70,6	3,48



CATENE A RULLI CON ATTACCHI VERTICALI - DIN 8187 - ISO 606

ROLLER CHAINS WITH VERTICAL ATTACHMENTS - DIN 8187 - ISO 606

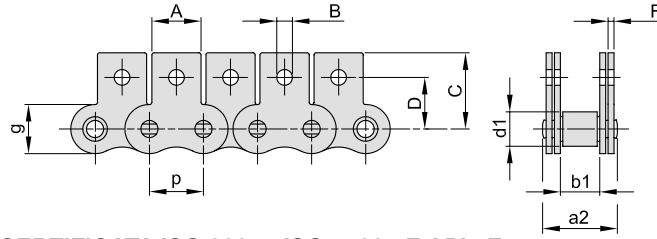

MK1/01

CATENA PRODOTTA DA AZIENDA CERTIFICATA ISO 9001 - ISO 14001 E API 7F
CHAIN PRODUCED BY ISO 9001 - ISO 14001 AND API 7F CERTIFIED COMPANY

CATENA PRESTIRATA / PRE-STRETCHED CHAINS

CONFEZIONE DA 5 MT



ISO	codice	p		b ₁ mm min.	d ₁ mm max.	a ₂ mm max.	g mm max.	A mm	B mm	C mm max.	D mm	F mm	Carico di rottura		q kg/m ≈
		mm	inch										minimo KN	medio KN	
06B-1	603109211	9,525	3/8"	5,72	6,35	13,5	8,26	8,0	3,5	13,5	9,5	1,03	9,0	10,7	0,61
08B-1	603112211	12,7	1/2"	7,75	8,51	17,0	11,81	9,5	4,3	18,4	14,1	1,40	18,0	21,1	1,01
10B-1	603115211	15,875	5/8"	9,65	10,16	19,6	14,73	14,1	5,2	24,7	15,9	1,63	22,4	27,4	1,32
12B-1	603119211	19,05	3/4"	11,68	12,07	22,7	16,13	15,8	5,6	26,6	17,9	1,80	29,0	32,3	1,66
16B-1	603125211	25,4	1"	17,02	15,88	36,1	21,08	19,0	6,8	35,0	26,0	3,00	60,0	70,6	4,27

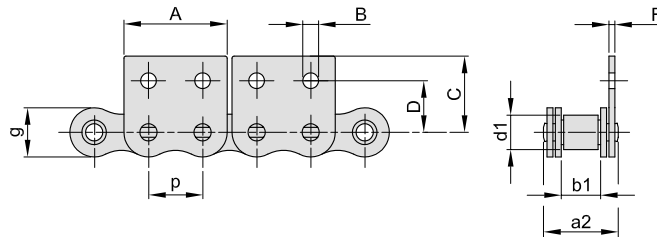

M2/02

CATENA PRODOTTA DA AZIENDA CERTIFICATA ISO 9001 - ISO 14001 E API 7F
CHAIN PRODUCED BY ISO 9001 - ISO 14001 AND API 7F CERTIFIED COMPANY

CATENA PRESTIRATA / PRE-STRETCHED CHAINS

CONFEZIONE DA 5 MT



ISO	codice	p		b ₁ mm min.	d ₁ mm max.	a ₂ mm max.	g mm max.	A mm	B mm	C mm max.	D mm	F mm	Carico di rottura		q kg/m ≈
		mm	inch										minimo KN	medio KN	
06B-1	603109122	9,525	3/8"	5,72	6,35	13,5	8,26	17,6	3,2	13,5	9,5	1,03	9,0	10,7	0,51
08B-1	603112122	12,7	1/2"	7,75	8,51	17,0	11,81	23,2	4,3	18,4	14,1	1,40	18,0	21,1	0,85
10B-1	603115122	15,875	5/8"	9,65	10,16	19,6	14,73	29,3	5,2	24,7	15,9	1,63	22,4	27,4	1,13
12B-1	603119122	19,05	3/4"	11,68	12,07	22,7	16,13	33,0	5,6	31,3	17,9	1,80	29,0	32,3	1,45
16B-1	603125122	25,4	1"	17,02	15,88	36,1	21,08	45,9	6,8	36,6	26,0	3,00	60,0	70,6	3,48

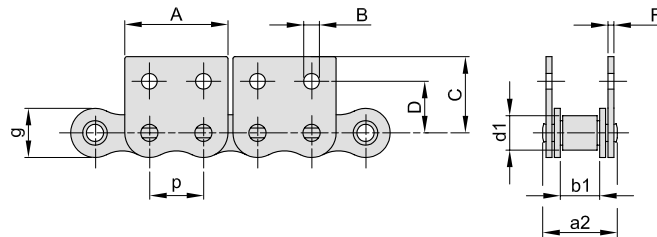

MK2/02

CATENA PRODOTTA DA AZIENDA CERTIFICATA ISO 9001 - ISO 14001 E API 7F
CHAIN PRODUCED BY ISO 9001 - ISO 14001 AND API 7F CERTIFIED COMPANY

CATENA PRESTIRATA / PRE-STRETCHED CHAINS

CONFEZIONE DA 5 MT



ISO	codice	p		b ₁ mm min.	d ₁ mm max.	a ₂ mm max.	g mm max.	A mm	B mm	C mm max.	D mm	F mm	Carico di rottura		q kg/m ≈
		mm	inch										minimo KN	medio KN	
06B-1	603109222	9,525	3/8"	5,72	6,35	13,5	8,26	17,6	3,2	13,5	9,5	1,03	9,0	10,7	0,61
08B-1	603112222	12,7	1/2"	7,75	8,51	17,0	11,81	23,2	4,3	18,4	14,1	1,40	18,0	21,1	1,01
10B-1	603115222	15,875	5/8"	9,65	10,16	19,6	14,73	29,3	5,2	24,7	15,9	1,63	22,4	27,4	1,32
12B-1	603119222	19,05	3/4"	11,68	12,07	22,7	16,13	33,0	5,6	31,3	17,9	1,80	29,0	32,3	1,66
16B-1	603125222	25,4	1"	17,02	15,88	36,1	21,08	45,9	6,8	36,6	26,0	3,00	60,0	70,6	3,78



CATENE A RULLI CON PERNI SPORGENTI - DIN 8187 - ISO 606 EXTENDED PIN CHAINS - DIN 8187 - ISO 606

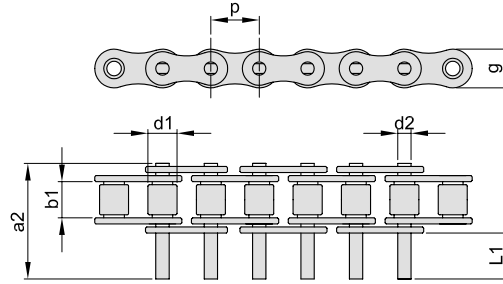

CATENA PRODOTTA DA AZIENDA CERTIFICATA ISO 9001 - ISO 14001 E API 7F
CHAIN PRODUCED BY ISO 9001 - ISO 14001 AND API 7F CERTIFIED COMPANY

CATENA PRESTIRATA / PRE-STRETCHED CHAINS

CONFEZIONE DA 5 MT



ISO	codice	p		b ₁ mm min.	d ₂ mm	d ₁ mm max.	L ₁ mm	a ₂ mm min.	g mm max.	Carico di rottura		q kg/m ≈
		mm	inch							minimo KN	medio KN	
06B-1	605109000	9,525	3/8"	5,72	3,28	6,35	11,10	22,75	8,26	9,0	10,7	0,47
08B-1	605112000	12,7	1/2"	7,75	4,45	8,51	15,15	30,91	11,81	18,0	21,1	0,75
10B-1	605115000	15,875	5/8"	9,65	5,08	10,16	17,63	35,26	14,73	22,4	27,4	1,07
12B-1	605119000	19,05	3/4"	11,68	5,72	12,07	20,83	41,66	16,13	29,0	32,3	1,22
16B-1	605125000	25,4	1"	17,02	8,28	15,88	33,80	67,58	21,08	60,0	70,6	3,03



CATENE PER ACCUMULO ACCUMULATOR CHAINS

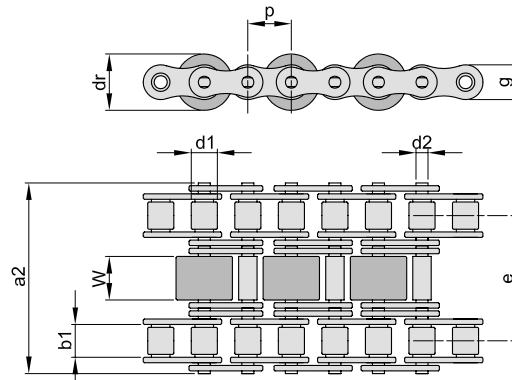

CATENA PRODOTTA DA AZIENDA CERTIFICATA ISO 9001 - ISO 14001 E API 7F
CHAIN PRODUCED BY ISO 9001 - ISO 14001 AND API 7F CERTIFIED COMPANY

CATENA PRESTIRATA / PRE-STRETCHED CHAINS

CONFEZIONE DA 5 MT



ISO	codice	p		b ₁ mm min.	d ₂ mm	d ₁ mm max.	a ₂ mm min.	g mm max.	e mm	dr mm max.	W mm	Carico di rottura		q kg/m ≈
		mm	inch									minimo KN	medio KN	
12B-3	602119000	19,05	3/4"	11,68	5,72	12,07	61,2	15,82	38,92	28,0	15,5	57,8	59,3	4,04



CATENE A RULLI NICHELATA - DIN 8187 - ISO 606

NICKEL PLATED ROLLER CHAINS - DIN 8187 - ISO 606

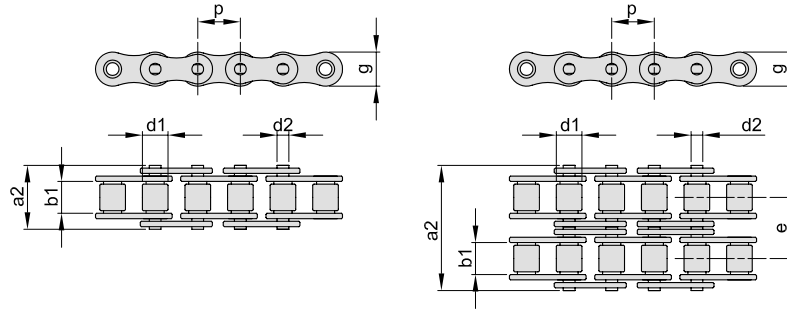

CATENA PRODOTTA DA AZIENDA CERTIFICATA ISO 9001 - ISO 14001 E API 7F
CHAIN PRODUCED BY ISO 9001 - ISO 14001 AND API 7F CERTIFIED COMPANY

CATENA PRESTIRATA / PRE-STRETCHED CHAINS



CONFEZIONE DA 5 MT

SEMPLICE

ISO	codice	p		b ₁ mm min.	d ₂ mm	d ₁ mm max.	a ₂ mm min.	g mm max.	Carico di rottura		q kg/m ≈
		mm	inch						minimo KN	medio KN	
06B-1	645109000	9,525	3/8"	5,72	3,28	6,35	13,5	8,26	9,0	10,7	0,40
08B-1	645112000	12,7	1/2"	7,75	4,45	8,51	17,0	11,81	18,0	21,1	0,68
10B-1	645115000	15,875	5/8"	9,65	5,08	10,16	19,6	14,73	22,4	27,4	0,91
12B-1	645119000	19,05	3/4"	11,68	5,72	12,07	22,7	16,13	29,0	32,3	1,12
16B-1	645125000	25,4	1"	17,02	8,28	15,88	36,1	21,08	60,0	70,6	2,59



DOPPIA

ISO	codice	p		b ₁ mm min.	d ₂ mm	d ₁ mm max.	a ₂ mm min.	g mm max.	e mm	Carico di rottura		q kg/m ≈
		mm	inch							minimo KN	medio KN	
06B-2	645109200	9,525	3/8"	5,72	3,28	6,35	23,8	8,26	10,24	16,9	19,2	0,76
08B-2	645112200	12,7	1/2"	7,75	4,45	8,51	31,0	11,81	13,92	32,0	38,0	1,31
10B-2	645115200	15,875	5/8"	9,65	5,08	10,16	36,2	14,73	16,59	44,5	57,3	1,79
12B-2	645119200	19,05	3/4"	11,68	5,72	12,07	42,2	16,13	19,46	57,8	65,7	2,22
16B-2	645125200	25,4	1"	17,02	8,28	15,88	68,0	21,08	31,88	113,7	137,5	5,03



CATENE A RULLI IN ACCIAIO "INOX AISI 304" - DIN 8187 - ISO 606

ROLLER CHAINS IN 304 STAINLESS STEEL - DIN 8187 - ISO 606

La catena INOX (AISI 304), costruita a rulli pieni, offre una particolare resistenza alla corrosione. Può essere utilizzata quindi in ambienti all'acqua, agli agenti chimici ed al calore. Opera a temperature da -20° a +400°.

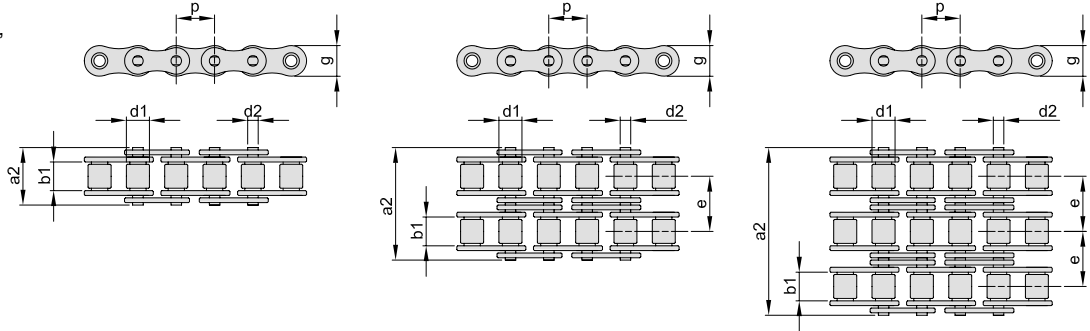

CATENA PRODOTTA DA AZIENDA CERTIFICATA ISO 9001 - ISO 14001 E API 7F
CHAIN PRODUCED BY ISO 9001 - ISO 14001 AND API 7F CERTIFIED COMPANY

CATENA PRESTIRATA / PRE-STRETCHED CHAINS



CONFEZIONE DA 5 MT

SEMPLICE

ISO	codice	p		b ₁ mm min.	d ₂ mm	d ₁ mm max.	a ₂ mm min.	g mm max.	Carico di rottura		q kg/m ≈
		mm	inch						minimo KN	medio KN	
06B-1	640109000	9,525	3/8"	5,72	3,28	6,35	13,5	8,26	6,6	6,9	0,40
08B-1	640112000	12,7	1/2"	7,75	4,45	8,51	17,0	11,81	12,0	12,7	0,68
10B-1	640115000	15,875	5/8"	9,65	5,08	10,16	19,6	14,73	15,0	16,8	0,91
12B-1	640119000	19,05	3/4"	11,68	5,72	12,07	22,7	16,13	17,0	17,5	1,12
16B-1	640125000	25,4	1"	17,02	8,28	15,88	36,1	21,08	40,0	41,0	2,59

DOPPIA

ISO	codice	p		b ₁ mm min.	d ₂ mm	d ₁ mm max.	a ₂ mm min.	g mm max.	e mm	Carico di rottura		q kg/m ≈
		mm	inch							minimo KN	medio KN	
06B-2	640109200	9,525	3/8"	5,72	3,28	6,35	23,8	8,26	10,24	10,5	12,8	0,76
08B-2	640112200	12,7	1/2"	7,75	4,45	8,51	31,0	11,81	13,92	22,0	24,4	1,31
10B-2	640115200	15,875	5/8"	9,65	5,08	10,16	36,2	14,73	16,59	28,4	33,8	1,79
12B-2	640119200	19,05	3/4"	11,68	5,72	12,07	42,2	16,13	19,46	33,3	35,6	2,22
16B-2	640125200	25,4	1"	17,02	8,28	15,88	68,0	21,08	31,88	74,4	79,0	5,03

TRIPLA

ISO	codice	p		b ₁ mm min.	d ₂ mm	d ₁ mm max.	a ₂ mm min.	g mm max.	e mm	Carico di rottura		q kg/m ≈
		mm	inch							minimo KN	medio KN	
06B-3	640109300	9,525	3/8"	5,72	3,28	6,35	34,0	8,26	10,24	17,8	18,6	1,12
08B-3	640112300	12,7	1/2"	7,75	4,45	8,51	44,9	11,81	13,92	30,6	31,8	1,94
10B-3	640115300	15,875	5/8"	9,65	5,08	10,16	52,8	14,73	16,59	42,6	49,5	2,68
12B-3	640119300	19,05	3/4"	11,68	5,72	12,07	61,7	16,13	19,46	50,0	52,2	3,32
16B-3	640125300	25,4	1"	17,02	8,28	15,88	99,9	21,08	31,88	111,7	117,6	7,65



CATENE A RULLI CON PIASTRE A PROFILO DIRITTO IN ACCIAIO "INOX AISI 304" - DIN 8187 - ISO 606
ROLLER CHAINS IN 304 STAINLESS STEEL WITH STRAIGHT PLATES - DIN 8187 - ISO 606

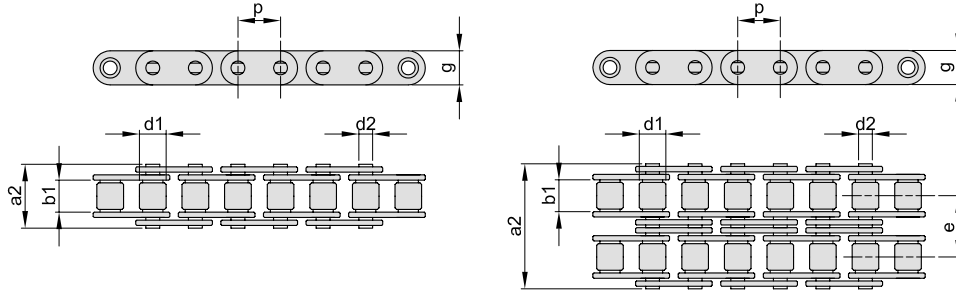

CATENA PRODOTTA DA AZIENDA CERTIFICATA ISO 9001 - ISO 14001 E API 7F
CHAIN PRODUCED BY ISO 9001 - ISO 14001 AND API 7F CERTIFIED COMPANY

CATENA PRESTIRATA / PRE-STRETCHED CHAINS



CONFEZIONE DA 5 MT

SEMPLICE

ISO	codice	p		b ₁ mm min.	d ₂ mm	d ₁ mm max.	a ₂ mm min.	g mm max.	Carico di rottura		q kg/m ≈
		mm	inch						minimo KN	medio KN	
08B-1	641112000	12,7	1/2"	7,75	4,45	8,51	17,0	11,6	12,0	12,7	0,78
12B-1	641119000	19,05	3/4"	11,68	5,72	12,07	22,7	15,9	17,0	17,5	1,30

DOPPIA

ISO	codice	p		b ₁ mm min.	d ₂ mm	d ₁ mm max.	a ₂ mm min.	g mm max.	e mm	Carico di rottura		q kg/m ≈
		mm	inch							minimo KN	medio KN	
08B-2	641112200	12,7	1/2"	7,75	4,45	8,51	31,0	11,6	13,92	22,0	24,4	1,55



CATENE A PERNI FORATI IN ACCIAIO "INOX AISI 304" - DIN 8187 - ISO 606
CHAINS IN 304 STAINLESS STEEL WITH HOLLOW PINS - DIN 8187 - ISO 606

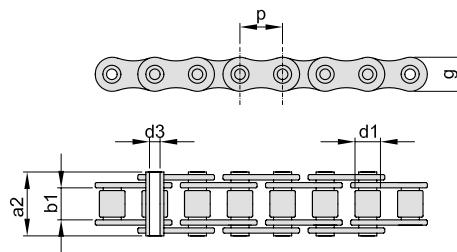

A RULLI

CATENA PRODOTTA DA AZIENDA CERTIFICATA ISO 9001 - ISO 14001 E API 7F
CHAIN PRODUCED BY ISO 9001 - ISO 14001 AND API 7F CERTIFIED COMPANY

CATENA PRESTIRATA / PRE-STRETCHED CHAINS



CONFEZIONE DA 5 MT

ISO	codice	p		b ₁ mm min.	d ₃ mm	d ₁ mm max.	a ₂ mm min.	g mm max.	Carico di rottura		q kg/m ≈
		mm	inch						minimo KN	medio KN	
08B-1	641512000	12,7	1/2"	7,75	4,50	8,51	17,0	11,6	8,3	10,6	0,58
10B-1	641515000	15,875	5/8"	9,65	5,18	10,16	19,6	14,5	11,8	13,9	0,77
12B-1	641519000	19,05	3/4"	11,68	5,85	12,07	22,7	15,9	12,0	17,2	0,98
16B-1	641525000	25,4	1"	17,02	8,33	15,88	36,1	20,5	20,0	36,0	2,21



GIUNTI E FALSE PER CATENA "BEA" CONNECTING LINK AND OFFSET LINK FOR ROLLER CHAINS "BEA"



Descrizione ISO	p mm	SERIE EUROPEA GIUNTI		FALSE	
		tipo	codice	tipo	codice
04-1	6	1	610106026		
05B-1	8	1	610108026		
05B-2	8	1	610108226		
06B-1	9,525	4	610109026	3	610109059
06B-2	9,525	4	610109226	3	610109259
06B-3	9,525	4	610109326	3	610109359
08B-1	12,7	1	610112026	3	610112059
08B-2	12,7	1	610112226	3	610112259
08B-3	12,7	1	610112326	3	610112359
10B-1	15,875	1	610115026	3	610115059
10B-2	15,875	1	610115226	3	610115259
10B-3	15,875	1	610115326	3	610115359
12B-1	19,05	1	610119026	3	610119059
12B-2	19,05	1	610119226	3	610119259
12B-3	19,05	1	610119326	3	610119359
16B-1	25,4	1	610125026	3	610125059
16B-2	25,4	1	610125226	3	610125259
16B-3	25,4	1	610125326	3	610125359
20B-1	31,75	2	610131026	3	610131059
20B-2	31,75	2	610131226	3	610131259
20B-3	31,75	2	610131326	3	610131359
24B-1	38,1	2	610138026	3	610138059
24B-2	38,1	2	610138226	3	610138259
24B-3	38,1	2	610138326	3	610138359
28B-1	44,45	2	610144026	3	610144059
28B-2	44,45	2	610144226	3	610144259
28B-3	44,45	2	610144326	3	610144359
32B-1	50,8	2	610150026	3	610150059
32B-2	50,8	2	610150226	3	610150259
32B-3	50,8	2	610150326	3	610150359
40B-1	63,5	2	610163026	3	610163059
40B-2	63,5	2	610163226	3	610163259

Descrizione ANSI	p mm	SERIE AMERICANA GIUNTI		FALSE	
		tipo	codice	tipo	codice
35-1	9,525	1	630035026	3	630035059
35-2	9,525	1	630035226	3	630035259
* 35-3	9,525	1	630035326	3	630035359
40-1	12,7	1	630040026	3	630040059
40-2	12,7	1	630040226	3	630040259
* 40-3	12,7	1	630040326	3	630040359
50-1	15,875	1	630050026	3	630050059
50-2	15,875	1	630050226	3	630050259
* 50-3	15,875	1	630050326	3	630050359
60-1	19,05	1	630060026	3	630060059
60-2	19,05	1	630060226	3	630060259
* 60-3	19,05	1	630060326	3	630060359
80-1	25,4	1	630080026	3	630080059
80-2	25,4	1	630080226	3	630080259
* 80-3	25,4	1	630080326	3	630080359
100-1	31,75	2	630100026	3	630100059
100-2	31,75	2	630100226	3	630100259
* 100-3	31,75	2	630100326	3	630100359
120-1	38,15	2	630120026	3	630120059
120-2	38,15	2	630120226	3	630120259
* 120-3	38,15	2	630120326	3	630120359
140-1	44,45	2	630140026	3	630140059
140-2	44,45	2	630140226	3	630140259
* 140-3	44,45	2	630140326	3	630140359
160-1	50,8	2	630160026	3	630160059
160-2	50,8	2	630160226	3	630160259
* 160-3	50,8	2	630160326	3	630160359
60-1H	19,05	1	631060026	3	631060059
80-1H	25,4	1	631080026	3	631080059
100-1H	31,75	2	631100026	3	631100059

* Costruiti a richiesta - manufactured on request.



GIUNTI E FALSE PER CATENA "BEA" CONNECTING LINK AND OFFSET LINK FOR ROLLER CHAINS "BEA"

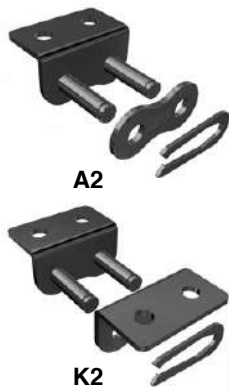
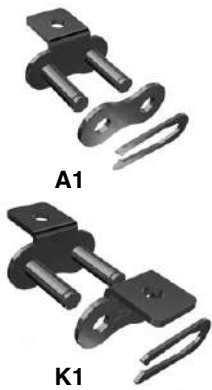

Descrizione ISO	ATTACCHI ANGOLARI - A1/02				
	p mm	GIUNTI		FALSE	
		tipo	codice	tipo	codice
06B-1	9,525	A1	614109110		
08B-1	12,7	A1	614112110		
10B-1	15,875	A1	614115110		
12B-1	19,05	A1	614119110		
16B-1	25,4	A1	614125110		

Descrizione ISO	ATTACCHI VERTICALI - M1-02				
	p mm	GIUNTI		FALSE	
		tipo	codice	tipo	codice
06B-1	9,525	M1	613109110		
08B-1	12,7	M1	613112110		
10B-1	15,875	M1	613115110		
12B-1	19,05	M1	613119110		
16B-1	25,4	M1	613125110		

Descrizione ISO	ATTACCHI ANGOLARI - K1/02				
	p mm	GIUNTI		FALSE	
		tipo	codice	tipo	codice
06B-1	9,525	K1	614109210		
08B-1	12,7	K1	614112210		
10B-1	15,875	K1	614115210		
12B-1	19,05	K1	614119210		
16B-1	25,4	K1	614125210		

Descrizione ISO	ATTACCHI VERTICALI - MK1-02				
	p mm	GIUNTI		FALSE	
		tipo	codice	tipo	codice
06B-1	9,525	MK1	613109210		
08B-1	12,7	MK1	613112210		
10B-1	15,875	MK1	613115210		
12B-1	19,05	MK1	613119210		
16B-1	25,4	MK1	613125210		

Descrizione ISO	ATTACCHI ANGOLARI - A1/01				
	p mm	GIUNTI		FALSE	
		tipo	codice	tipo	codice
06B-1	9,525	A1	614109110		
08B-1	12,7	A1	614112110		
10B-1	15,875	A1	614115110		
12B-1	19,05	A1	614119110		
16B-1	25,4	A1	614125110		

Descrizione ISO	ATTACCHI VERTICALI - M1-01				
	p mm	GIUNTI		FALSE	
		tipo	codice	tipo	codice
06B-1	9,525	M1	613109110		
08B-1	12,7	M1	613112110		
10B-1	15,875	M1	613115110		
12B-1	19,05	M1	613119110		
16B-1	25,4	M1	613125110		

Descrizione ISO	ATTACCHI ANGOLARI - K1/01				
	p mm	GIUNTI		FALSE	
		tipo	codice	tipo	codice
06B-1	9,525	K1	614109210		
08B-1	12,7	K1	614112210		
10B-1	15,875	K1	614115210		
12B-1	19,05	K1	614119210		
16B-1	25,4	K1	614125210		

Descrizione ISO	ATTACCHI VERTICALI - MK1/01				
	p mm	GIUNTI		FALSE	
		tipo	codice	tipo	codice
06B-1	9,525	MK1	613109210		
08B-1	12,7	MK1	613112210		
10B-1	15,875	MK1	613115210		
12B-1	19,05	MK1	613119210		
16B-1	25,4	MK1	613125210		

Descrizione ISO	ATTACCHI ANGOLARI - A2/02				
	p mm	GIUNTI		FALSE	
		tipo	codice	tipo	codice
06B-1	9,525	A2	614109120		
08B-1	12,7	A2	614112120		
10B-1	15,875	A2	614115120		
12B-1	19,05	A2	614119120		
16B-1	25,4	A2	614125120		

Descrizione ISO	ATTACCHI VERTICALI - M2/02				
	p mm	GIUNTI		FALSE	
		tipo	codice	tipo	codice
06B-1	9,525	M2	613109120		
08B-1	12,7	M2	613112120		
10B-1	15,875	M2	613115120		
12B-1	19,05	M2	613119120		
16B-1	25,4	M2	613125120		

Descrizione ISO	ATTACCHI ANGOLARI - K2/02				
	p mm	GIUNTI		FALSE	
		tipo	codice	tipo	codice
06B-1	9,525	K2	614109220		
08B-1	12,7	K2	614112220		
10B-1	15,875	K2	614115220		
12B-1	19,05	K2	614119220		
16B-1	25,4	K2	614125220		

Descrizione ISO	ATTACCHI VERTICALI - MK2/02				
	p mm	GIUNTI		FALSE	
		tipo	codice	tipo	codice
06B-1	9,525	MK2	613109220		
08B-1	12,7	MK2	613112220		
10B-1	15,875	MK2	613115220		
12B-1	19,05	MK2	613119220		
16B-1	25,4	MK2	613125220		



GIUNTI E FALSE PER CATENA "BEA" CONNECTING LINK AND OFFSET LINK FOR ROLLER CHAINS "BEA"

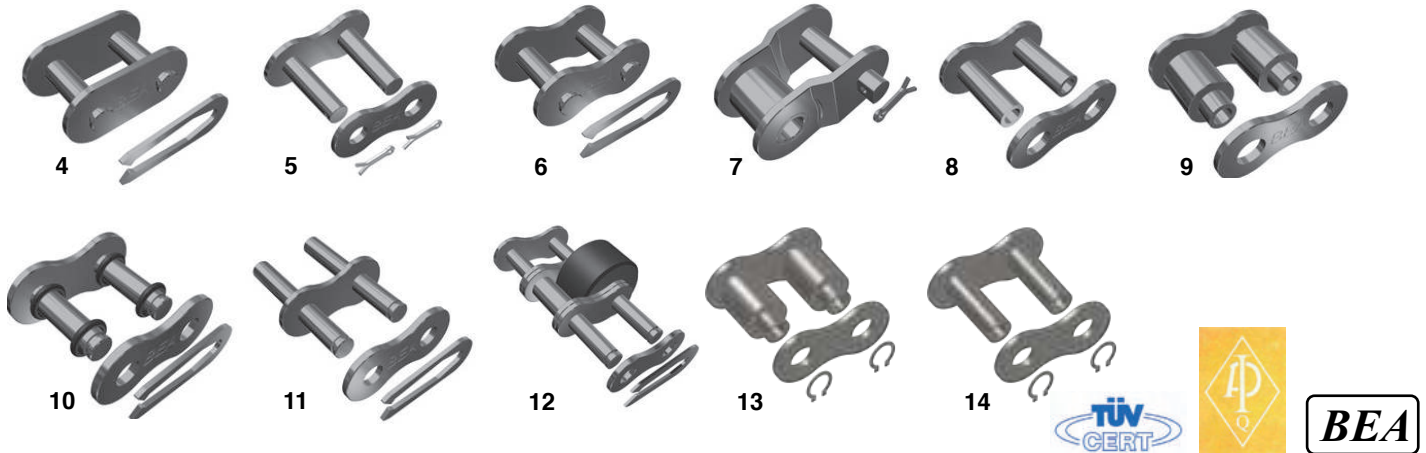

Descrizione ISO	PIASTRE A PROFILO DIRITTO GIUNTI				
	p mm	tipo	codice	tipo	FALSE codice
08B-1	12,7	4	611112026		
10B-1	15,875	4	611115026		
10B-2	15,875	4	611115226		
12B-1	19,05	4	611119026		
12B-2	19,05	4	611119226		
16B-1	25,4	4	611125026		
16B-2	25,4	4	611125226		
20B-1	31,75	5	611131026		
20B-2	31,75	5	611131226		

Descrizione ISO	NICHELATA GIUNTI				
	p mm	tipo	codice	tipo	FALSE codice
06B-1	9,525	6	646109026	7	646109059
06B-2	9,525	6	646109226	7	646109259
08B-1	12,7	6	646112026	7	646112059
08B-2	12,7	6	646112226	7	646112259
10B-1	15,875	6	646115026	7	646115059
10B-2	15,875	6	646115226	7	646115259
12B-1	19,05	6	646119026	7	646119059
12B-2	19,05	6	646119226	7	646119259
16B-1	25,4	6	646125026	7	646125059
16B-2	25,4	6	646125226	7	646125259

Descrizione ISO	PERNO FORATO TIPO "A" - A BUSSOLA GIUNTI				
	p mm	tipo	codice	tipo	FALSE codice
08B-1	12,7	14	611512026		
10B-1	15,875	8	611515026		
12B-1	19,05	8	611519026		

Descrizione ISO	PERNO FORATO TIPO "B" - A RULLI GIUNTI				
	p mm	tipo	codice	tipo	FALSE codice
08B-1	12,7	9	611612026		
10B-1	15,875	13	611615026		
12B-1	19,05	13	611619026		
16B-1	25,4	13	611625026		

Descrizione ISO	AUTOLUBRIFICATA GIUNTI				
	p mm	tipo	codice	tipo	FALSE codice
08B-1	12,7				
10B-1	15,875				
12B-1	19,05				

Descrizione ISO	"O-RING" GIUNTI				
	p mm	tipo	codice	tipo	FALSE codice
08B-1	12,7	10	644112026		
10B-1	15,875	10	644115026		

Descrizione ISO	PERNI SPORGENTI GIUNTI				
	p mm	tipo	codice	tipo	FALSE codice
06B-1	9,525	11	615109026		
08B-1	12,7	11	615112026		
10B-1	15,875	11	615115026		
12B-1	19,05	11	615119026		
16B-1	25,4	11	615125026		

Descrizione ISO	ACCUMULO GIUNTI				
	p mm	tipo	codice	tipo	FALSE codice
12B-3	19,50	12	612119026		



GIUNTI E FALSE PER CATENA INOX "BEA"

CONNECTING LINK AND OFFSET LINK FOR ROLLER CHAINS IN STAINLESS STEEL "BEA"



1



3



4



9



13



Descrizione ISO	p mm	SERIE EUROPEA			FALSE codice
		GIUNTI		tipo	
		tipo	codice	tipo	
06B-1	9,525	4	650109026	3	650109059
06B-2	9,525	4	650109226	3	650109259
06B-3	9,525	4	650109326	3	650109359
08B-1	12,7	1	650112026	3	650112059
08B-2	12,7	1	650112226	3	650112259
08B-3	12,7	1	650112326	3	650112359
10B-1	15,875	1	650115026	3	650115059
10B-2	15,875	1	650115226	3	650115259
10B-3	15,875	1	650115326	3	650115359
12B-1	19,05	1	650119026	3	650119059
12B-2	19,05	1	650119226	3	650119259
12B-3	19,05	1	650119326	3	650119359
16B-1	25,4	1	650125026	3	650125059
16B-2	25,4	1	650125226	3	650125259
16B-3	25,4	1	650125326	3	650125359

Descrizione ANSI	p mm				FALSE codice
		GIUNTI		tipo	
		tipo	codice	tipo	

Descrizione ISO	p mm	PIASTRE A PROFILO DIRITTO			FALSE codice
		GIUNTI		tipo	
		tipo	codice	tipo	
08B-1	12,7	4	651112026		
08B-2	12,7	4	651112226		
12B-1	19,05	4	651119026		

Descrizione ANSI	p mm	PERNI FORATI - A RULLI			FALSE codice
		GIUNTI		tipo	
		tipo	codice	tipo	
08B-1	12,7	13	651512026		
10B-1	15,875	9	651515026		
12B-1	19,05	9	651519026		
16B-1	25,4	9	651525026		