



# PIGNONI PER CATENA A RULLI CON TEMPERA INDUZIONE SUI DENTI SPROCKETS FOR ROLLER CHAINS WITH HARDENED TEETH

**3/8" x 7/32"**  
9,525 x 5,71 mm  
Rullo 6,35 mm  
**06B - 1 - 2**

B1	B2	B3	b1	C	r3
5,3	15,4		5,2	1	10

Materiale: Acciaio C-45

Z	de	dp	semplici				doppi					
			codice	dm	D1	A	Kg.	codice	dm	D2	A	Kg.
13	43,5	39,80	191330013	28	8	25	0,13	192330013	28	10	30	0,16
14	46,5	42,80	191330014	31	8	25	0,16	192330014	31	10	30	0,20
15	49,5	45,81	191330015	34	8	25	0,19	192330015	34	10	30	0,24
16	52,5	48,82	191330016	37	10	28	0,24	192330016	37	12	30	0,27
17	55,5	51,83	191330017	40	10	28	0,28	192330017	40	12	30	0,32
18	58,6	54,85	191330018	43	10	28	0,33	192330018	43	12	30	0,38
19	61,6	57,87	191330019	45	10	28	0,36	192330019	46	12	30	0,42
20	64,6	60,89	191330020	46	10	28	0,39	192330020	49	12	30	0,48
21	67,6	63,91	191330021	48	12	28	0,42	192330021	52	16	30	0,52
22	70,6	66,93	191330022	50	12	28	0,46	192330022	55	16	30	0,58
23	73,7	69,95	191330023	52	12	28	0,50	192330023	58	16	30	0,64
24	76,7	72,97	191330024	54	12	28	0,54	192330024	61	16	30	0,71
25	79,7	76,00	191330025	57	12	28	0,60	192330025	64	16	30	0,79
30	94,8	91,12	191330030	60	12	30	0,72	192330030	79	16	30	1,20

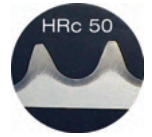
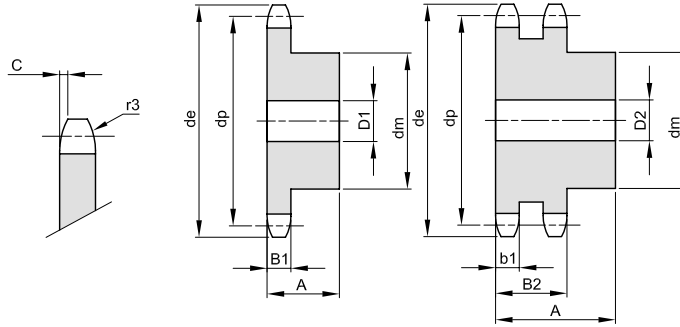

# PIGNONI PER CATENA A RULLI CON TEMPERA INDUZIONE SUI DENTI SPROCKETS FOR ROLLER CHAINS WITH HARDENED TEETH

**1/2" x 5/16"**  
12,7 x 7,75 mm  
Rullo 8,51 mm  
**08B - 1 - 2**

B1	B2	B3	b1	C	r3
7,2	21		7	1,3	13

Materiale: Acciaio C-45

Z	de	dp	semplici				doppi					
			codice	dm	D1	A	Kg.	codice	dm	D2	A	Kg.
12	53,9	49,07	191340012	33	10	28	0,21	192340012	35	12	35	0,30
13	57,9	53,06	191340013	37	10	28	0,26	192340013	38	12	35	0,36
14	61,9	57,07	191340014	41	10	28	0,32	192340014	42	12	35	0,44
15	65,9	61,09	191340015	45	10	28	0,38	192340015	46	12	35	0,52
16	69,9	65,10	191340016	50	12	28	0,46	192340016	50	16	38	0,63
17	74,0	69,11	191340017	52	12	28	0,51	192340017	54	16	38	0,73
18	78,0	73,14	191340018	56	12	28	0,59	192340018	58	16	38	0,85
19	82,0	77,16	191340019	60	12	28	0,67	192340019	62	16	38	0,97
20	86,0	81,19	191340020	64	12	28	0,76	192340020	66	16	38	1,10
21	90,1	85,22	191340021	68	14	28	0,85	192340021	70	16	40	1,29
22	94,1	89,24	191340022	70	14	28	0,91	192340022	70	16	40	1,37
23	98,1	93,27	191340023	70	14	28	0,95	192340023	70	16	40	1,46
24	102,1	97,29	191340024	70	14	28	0,98	192340024	75	16	40	1,64
25	106,2	101,33	191340025	70	14	28	1,01	192340025	80	16	40	1,82
30	126,3	121,50	191340030	80	16	30	1,46	192340030	100	16	40	2,79

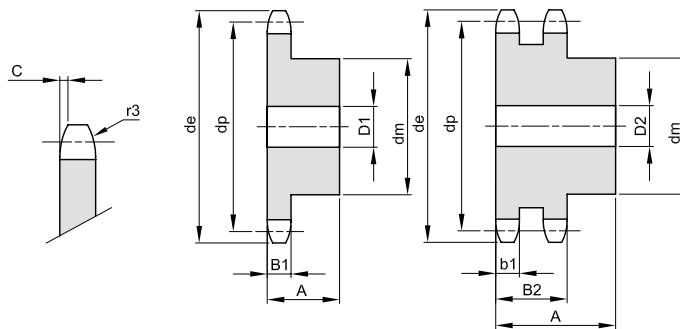



# PIGNONI PER CATENA A RULLI CON TEMPERA INDUZIONE SUI DENTI SPROCKETS FOR ROLLER CHAINS WITH HARDENED TEETH

**5/8" x 3/8"**  
15,875 x 9,65 mm  
Rullo 10,16 mm  
10B - 1 - 2

B1	B2	B3	b1	C	r3
9,1	25,5		9	1,6	16

Materiale: Acciaio C-45

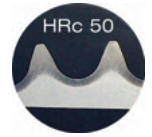
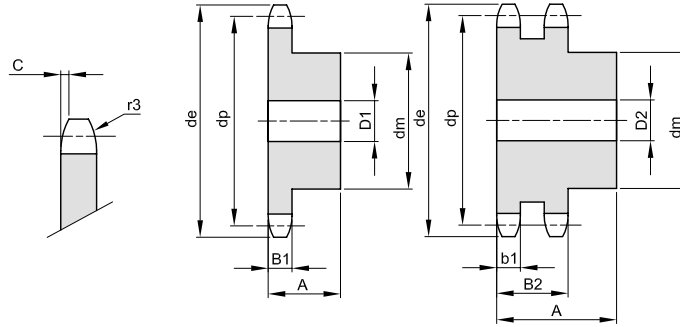

Z	de	dp	semplici				doppi					
			codice	dm	D1	A	Kg.	codice	dm	D2	A	Kg.
12	68,2	61,34	191350012	42	12	30	0,37	192350012	44	16	40	0,55
13	73,2	66,32	191350013	47	12	30	0,46	192350013	49	16	40	0,68
14	78,2	71,34	191350014	52	12	30	0,56	192350014	54	16	40	0,82
15	83,2	76,36	191350015	57	12	30	0,67	192350015	59	16	40	0,97
16	88,3	81,37	191350016	60	12	30	0,76	192350016	64	16	45	1,26
17	93,3	86,39	191350017	60	12	30	0,88	192350017	69	16	45	1,46
18	98,3	91,42	191350018	70	14	30	1,01	192350018	74	16	45	1,67
19	103,3	96,45	191350019	70	14	30	1,15	192350019	79	16	45	1,90
20	108,4	101,49	191350020	75	14	30	1,21	192350020	84	16	45	2,14
21	113,4	106,52	191350021	75	16	30	1,35	192350021	85	16	45	2,27
22	118,4	111,55	191350022	80	16	30	1,41	192350022	90	16	45	2,54
23	123,5	116,58	191350023	80	16	30	1,47	192350023	95	16	45	2,82
24	128,5	121,62	191350024	80	16	30	1,54	192350024	100	16	45	3,11
25	133,6	126,66	191350025	80	16	30	1,60	192350025	105	16	45	3,15
30	158,8	151,87	191350030	90	20	35	2,41	192350030	120	20	45	4,87



# PIGNONI PER CATENA A RULLI CON TEMPERA INDUZIONE SUI DENTI SPROCKETS FOR ROLLER CHAINS WITH HARDENED TEETH

**3/4" x 7/16"**  
19,50 x 11,68 mm  
Rullo 12,07 mm  
12B - 1 - 2

B1	B2	B3	b1	C	r3
11,1	30,3		10,8	2	19

Materiale: Acciaio C-45

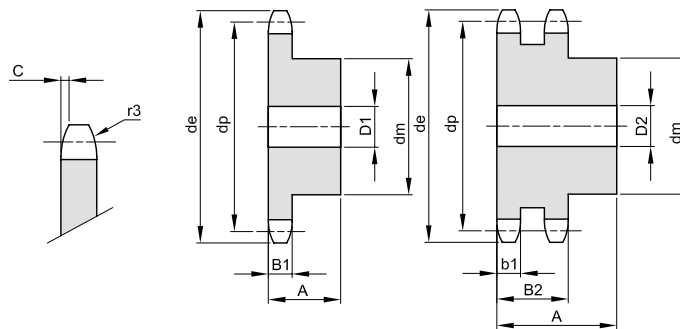

Z	de	dp	semplici				doppi					
			codice	dm	D1	A	Kg.	codice	dm	D2	A	Kg.
12	81,8	73,60	191360012	52	16	35	0,65	192360012	53	16	50	1,02
13	87,8	79,59	191360013	58	16	35	0,80	192360013	59	16	50	1,25
14	93,8	85,61	191360014	64	16	35	0,97	192360014	65	16	50	1,46
15	99,8	91,63	191360015	70	16	35	1,16	192360015	71	16	50	1,74
16	105,8	97,65	191360016	75	16	35	1,34	192360016	77	20	50	2,03
17	111,9	103,67	191360017	80	16	35	1,53	192360017	83	20	50	2,36
18	117,9	109,71	191360018	80	16	35	1,62	192360018	89	20	50	2,70
19	123,9	115,75	191360019	80	16	35	1,70	192360019	95	20	50	3,07
20	130,0	121,78	191360020	80	16	35	1,80	192360020	100	20	50	3,43
21	136,0	127,82	191360021	90	20	40	2,35	192360021	100	20	50	3,69
22	142,0	133,86	191360022	90	20	40	2,46	192360022	100	20	50	3,97
23	148,1	139,90	191360023	90	20	40	2,56	192360023	110	20	50	4,51
24	154,1	145,94	191360024	90	20	40	2,68	192360024	110	20	50	4,81
25	160,2	152,00	191360025	90	20	40	2,80	192360025	120	20	50	5,41
30	190,4	182,25	191360030	95	20	40	3,63	192360030	120	20	50	7,19

